

SLIDE GUIDE

GL TYPE

The NB slide guide GL type realized low noise with a ball cushion embedded between the steel balls and significantly extended lubricant replenishment intervals by the use of fiber sheet. In addition, its compact size as well as high load capacity allows for the size and weight of machinery and other equipment to be reduced.

STRUCTURE AND ADVANTAGES

The GL type slide guide consists of a rail with 4 rows of precisely machined raceway groove and a block assembly consisting of the main body, steel balls, ball cushions, a retainer, a fiber sheet, and return caps.

Low Noise:

By incorporating a ball cushion between steel balls, the metal contact between the steel balls is prevented, which allows for a reduction in noise levels. (See the noise data in Fig. A-44, page A-53.)

Can Significantly Extend Lubricant Replenishment Intervals:

A lubricant-containing fiber sheet incorporated in the block supplies appropriate amount of lubricant to the raceway grooves at appropriate intervals, which can significantly extend the lubricant replenishment interval.

High Load Capacity and Long Life:

With large-diameter steel balls employed, this slide guide has a higher load rating and a longer life compared to low-noise guides offered by other companies.

(See the load rating comparison data in Fig. A-44, page A-53.)

Omni-Directional Load Capacity:

The steel balls are positioned at 45° contact angle so that the load capacity is equal in four directions (above, underneath, right and left).

Figure A-50 Structure of GL type Slide Guide

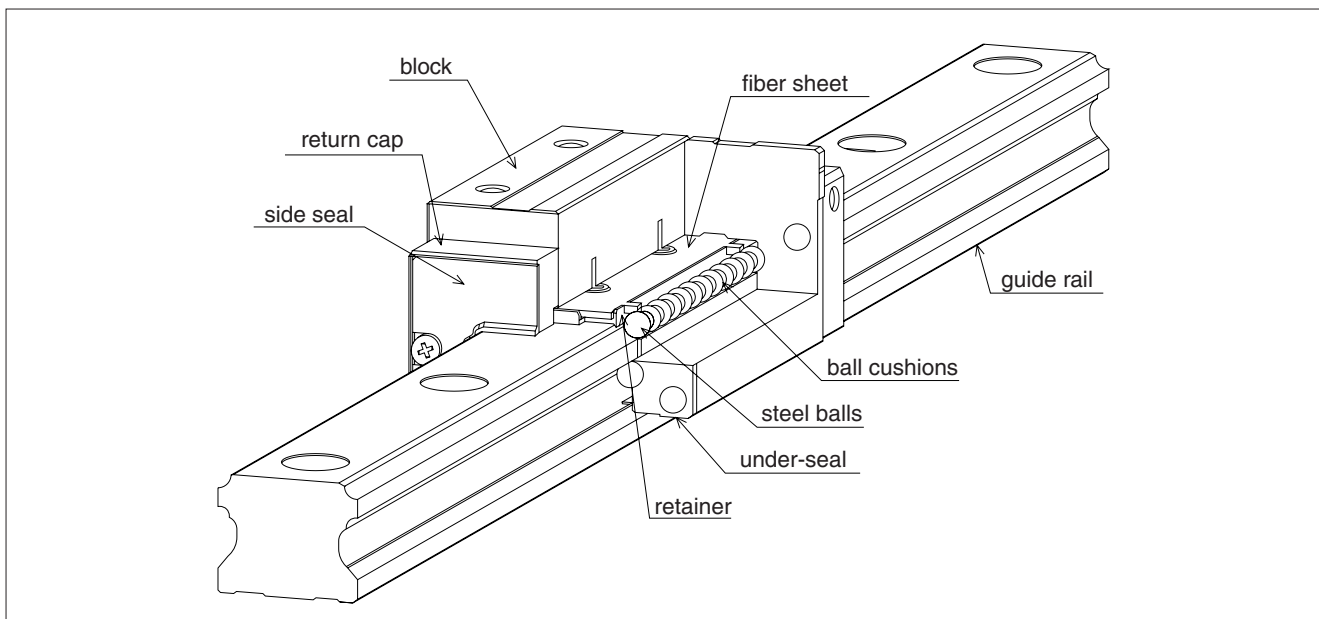

BLOCK TYPES

Six different types of blocks are available depending on the mounting space and desired mounting method.

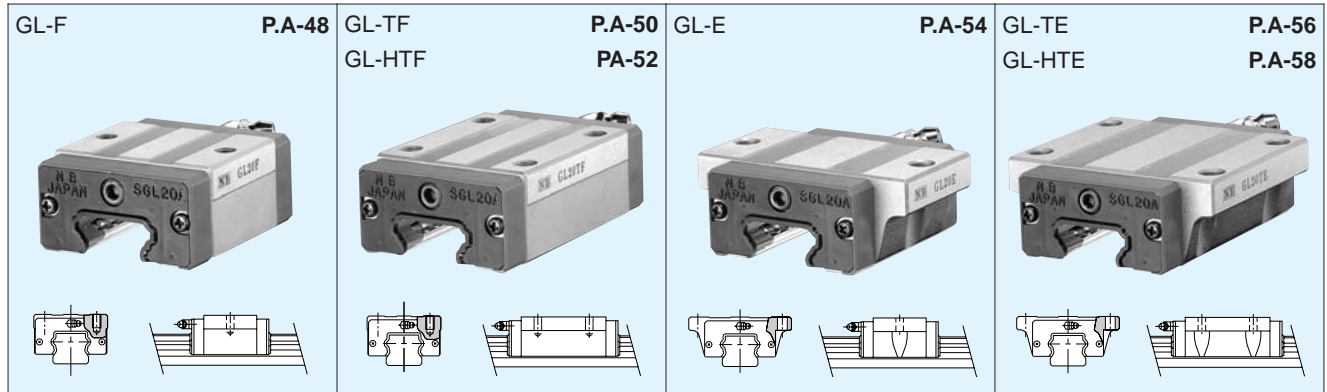

ACCURACY

Three accuracy grades are available: normal-grade (no suffix), high-grade (H), and precision-grade (P).

Table A-22 Accuracy

unit/mm

part number	GL15,20			GL25,30,35			GL45		
accuracy grade	normal	high	precision	normal	high	precision	normal	high	precision
accuracy symbol	none	H	P	none	H	P	none	H	P
allowable dimensional tolerance for height H	±0.1	±0.03	-0.03~0	±0.1	±0.04	-0.04~0	±0.1	±0.05	-0.05~0
paired difference for height H	0.02	0.01	0.006	0.02	0.015	0.007	0.03	0.015	0.007
allowable dimensional tolerance for width W	±0.1	±0.03	-0.03~0	±0.1	±0.04	-0.04~0	±0.1	±0.05	-0.05~0
paired difference for width W	0.02	0.01	0.006	0.03	0.015	0.007	0.03	0.02	0.01
Running parallelism of surface C to surface A	refer to Figure A-51								
Running parallelism of surface D to surface B									

Figure A-51 Motion Accuracy

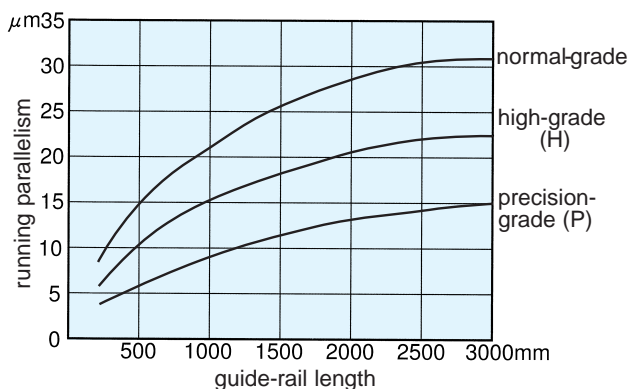
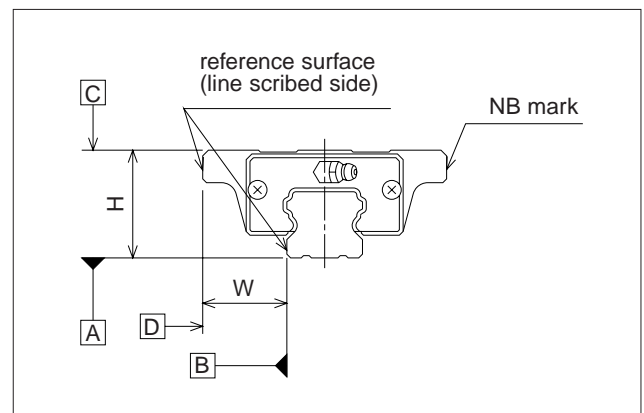

Figure A-52 Accuracy



Low Noise

Ball cushions are inserted between the steel balls preventing metal contact and enabling low noise.

Figure A-53 Noise Data

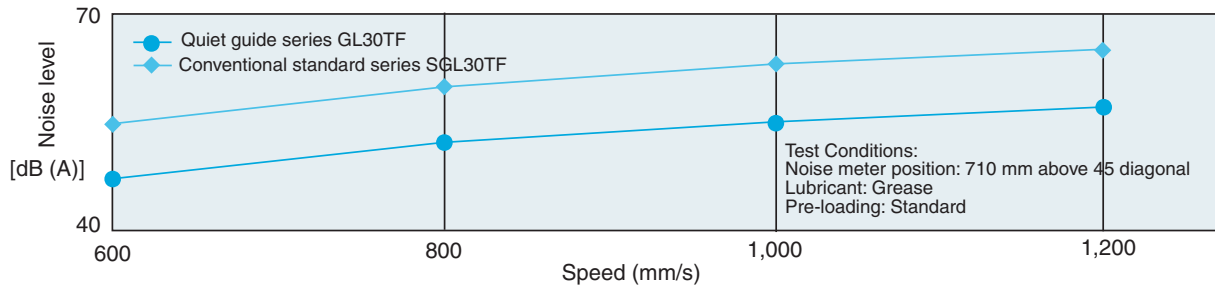

High load capacity / long life

The GL type slide guide has a rated load of 1.2 to 1.6 times greater than the load of other companies "low-noise" type guides. This high load capacity enables a longer service life.

Figure A-54 Rated load comparison data

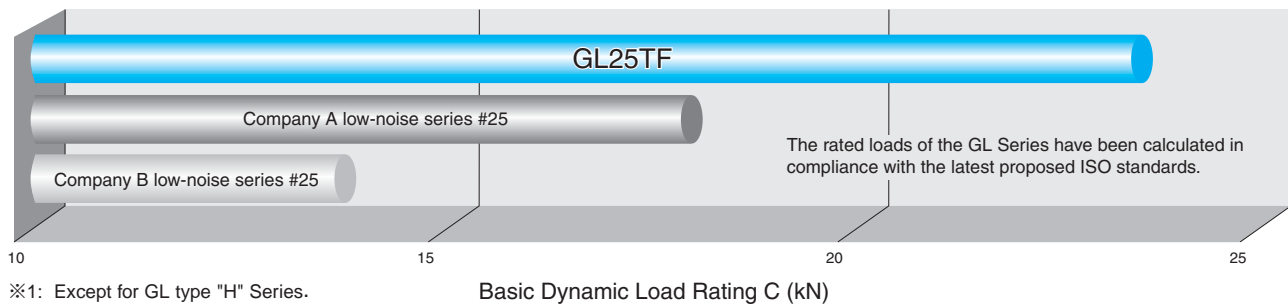

Clean Operation

Ball cushions eliminate metal contact between the steel balls and prevent excess grease spatter, enabling linear operation with low levels of dust generation.

Figure A-55 Dust generation data

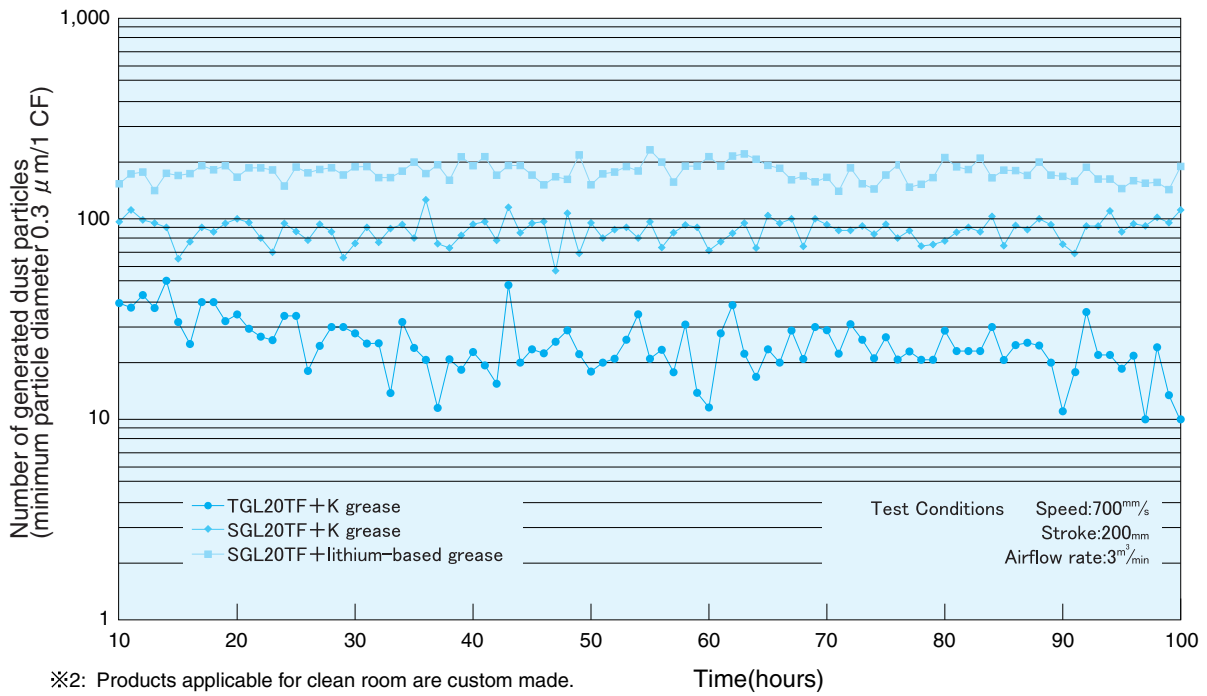

PRE-LOAD

GL type slide guides are available with a standard pre-load (no suffix), light pre-load (T1), and medium pre-load (T2).

Table A-23 Pre-load Symbol and Radial Clearance unit/ μm

pre-load category	standard	light	medium
pre-load symbol	none	T1	T2
GL15	- 4~+2	-12~- 4	-
GL20	- 5~+2	-14~- 5	-23~-14
GL25	- 6~+3	-16~- 6	-26~-16
GL30	- 7~+4	-19~- 7	-31~-19
GL35	- 8~+4	-22~- 8	-35~-22
GL45	-10~+5	-25~-10	-40~-25

Table A-24 Operating Condition and Pre-Load

category	symbol	operating condition
standard	none	Minute vibration is applied. Precision motion is required. Moment in a given direction is applied.
light	T1	Light vibration is applied. Light combined load is applied. Moment is applied.
medium	T2	Shock/vibration is applied. Over-hang load is applied. Combined load is applied.

RAIL LENGTH

Slide guides with most commonly used lengths are available as standard. Unless otherwise specified, the distance to the first mounting hole (N) from one end of the rail will be located within the range listed in Table A-25 for slide guides that have a non-standard length satisfying the following equation.

$$L = M \cdot P + 2N$$

L : length (mm) N : distance to the first hole from the end of the rail (mm)
M : number of pitches P : hole pitch (mm)

Table A-25 Fabrication Range

unit/mm

part number	N		Lmax
	and over	less than	
GL15	6	36	2,000
GL20	10	40	
GL25	11	41	
GL30	12	52	
GL35	16	56	
GL45	20	60	

Figure A-57 Rail

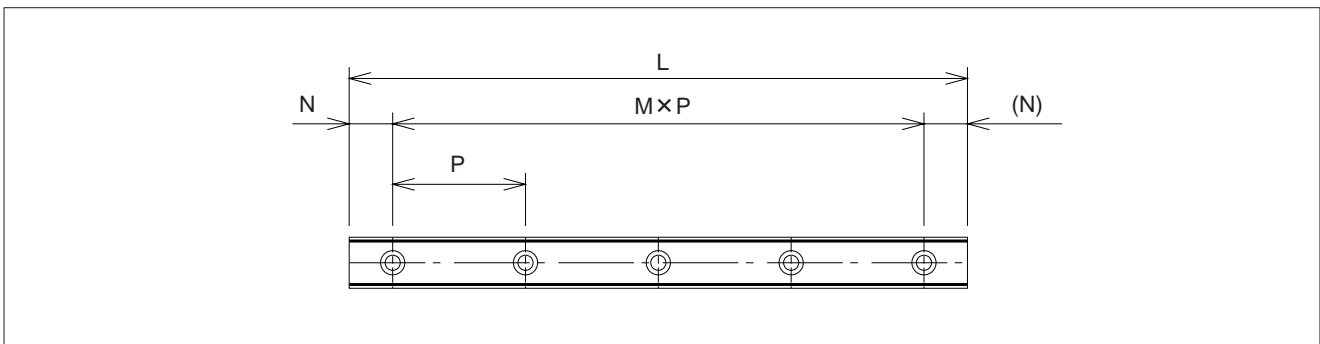

MOUNTING

As shown in Figure A-58, the standard method of slide guide mounting is to bring the reference surface of the rail and/or block into contact with the shoulder on the mounting surface. The shape of the shoulder should be finished to no more than the value shown in Table A-27, to prevent interfere with the corner of the rail or block.

Use a torque wrench to attach the rail with the set torque, to ensure the precision performances. The recommended torque values are shown in Table A-26. Adjust the torque value as needed according to the operating conditions.

Table A-26 Recommended Torque unit/N•m

bolt size	M3	M4	M5	M6	M8	M12
recommended torque	1.4	3.2	6.6	11.2	27.6	96.4

(When using alloy steel bolts)

Figure A-58 Mounting Reference Surface Shapes

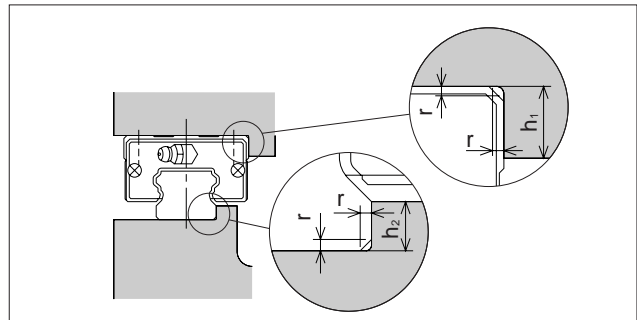

Table A-27 Mounting Surface Dimensions unit/mm

part number	h ₁	h ₂	r _{max}
SGL15	4	3.5	0.5
SGL20	5	5	0.5
SGL25	5	5.5	1
SGL30	6	7.5	1
SGL35	6	8	1
SGL45	8	8	1

GREASE FITTING

A grease fitting is attached to the GL slide guide in the return cap for lubrication purposes. Unless otherwise specified, the orientation of the grease fitting is as shown in Figure A-59. When more than two blocks are used on one rail, the grease fitting orientation must be specified.

Figure A-59 Number of Blocks and Grease Fitting Orientation

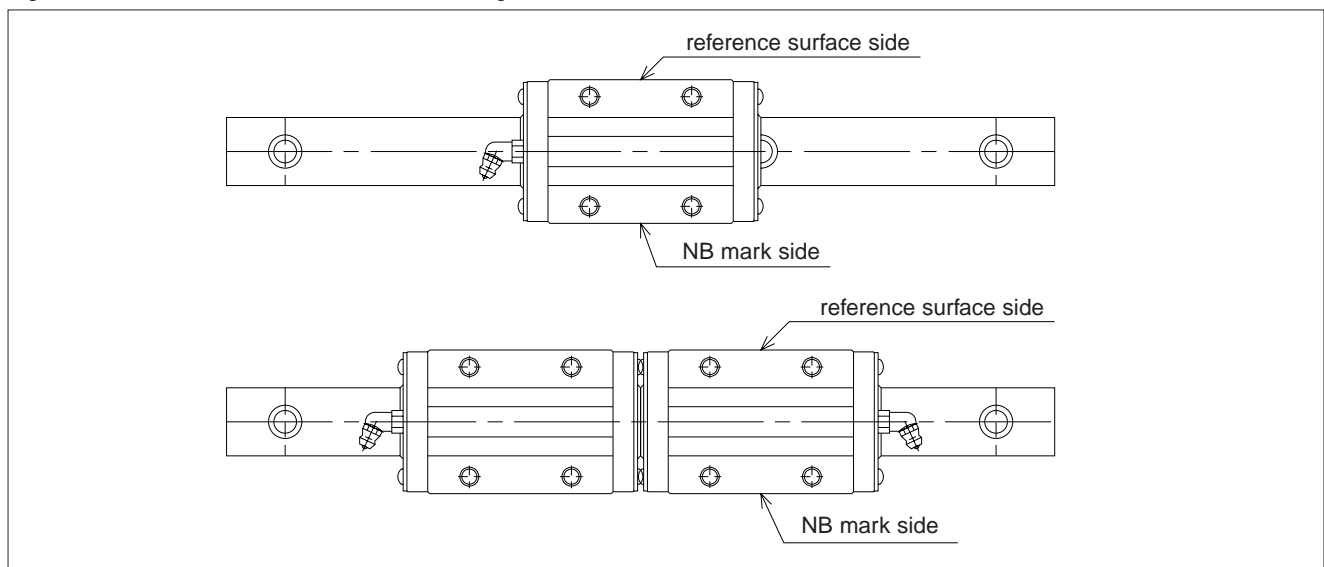

GL-F TYPE

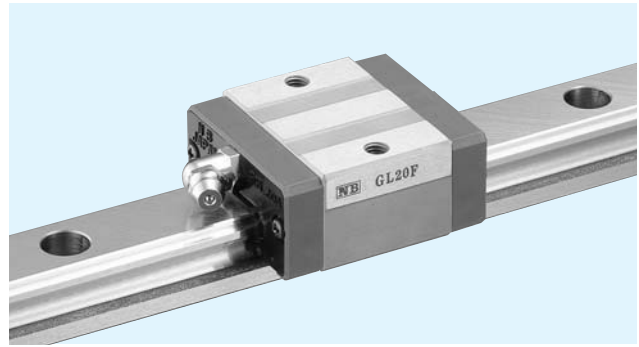

part number structure example **GL 15 F B 2 T1 - 589 D P / W2 RD F J KGL**

GL type
 size
 block style
 seal(refer to page A-14)

B(standard)	With side seals + under-seal
BW	With double seals + under-seal
BS	B + scraper

number of blocks per rail
 symbol for pre-load

blank	standard
T1	light
T2	medium

total length of rail
 size of rail installation hole(D type rail is available only for GL 15)
 accuracy grade

blank	standard
H	high
P	precision

symbol for grease

blank	standard grease w/fiber sheet
KGL	lithum-based grease w/o fiber sheet
KGU	urea-based grease w/o fiber sheet
KGF	anti-fretting grease w/o fiber sheet
GK	K-grease w/o fiber sheet

refer to page Eng-20 for details on special grease
 Fiber sheet is omitted when special grease is specified.

with bellows(refer to page A-16)
 with rail mounting hole caps
 with Raydent treatment

symbol for number of rails

blank	single rail
W2	double rails
W3	triple rails

The symbol for the number of rails does not mean the number of rail ordered.

part number	assembly dimensions		block dimensions											
	H	W	B	L ₁	L ₂	L ₃	L ₄	P ₁	S ₁	ℓ	T	b	E ₁	E ₂
	mm	mm	mm	mm	mm	mm	mm	mm		mm	mm	mm	mm	mm
GL15F GL15F-D	24	9.5	34	40.7	22.7	46.9	47.3	26	M4	7	6	19.5	5	5.4
GL20F	28	11	42	47.9	29.5	54.1	54.5	32	M5	8	7.5	22	14	13.3
GL25F	33	12.5	48	58.7	37.7	65.1	65.9	35	M6	9	8	26		13.1
GL30F	42	16	60	68	40	76.6	75.6	40	M8	12	9	32.5		14
GL35F	48	18	70	77	46	85.6	84.6	50			13	38		

part number	standard rail length															
	L mm															
GL15	160	220	280	340	400	460	520	580	640	700	760	820	880	940	1,000	1,120
GL20	220	280	340	400	460	520	580	640	700	760	820	880	940	1,000	1,120	1,240
GL25	220	280	340	400	460	520	580	640	700	760	820	880	940	1,000	1,120	1,240
GL30	280	360	440	520	600	680	760	840	920	1,000	1,080	1,160	1,240	1,320	1,400	1,480
GL35	280	360	440	520	600	680	760	840	920	1,000	1,080	1,160	1,240	1,320	1,400	1,480

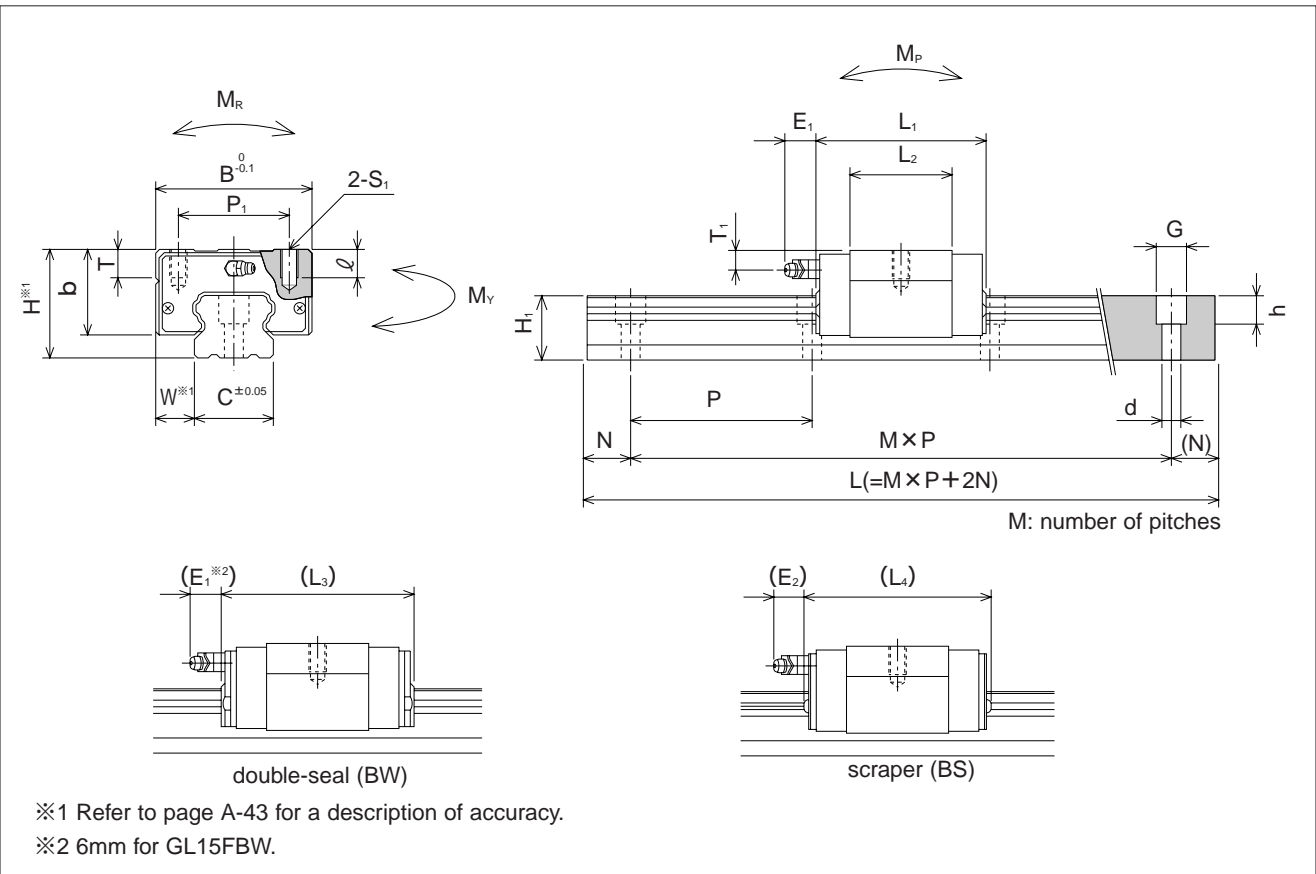

T ₁ mm	grease fitting	guide-rail dimensions					basic load rating		allowable static moment			mass		size
		H ₁ mm	C mm	d × G × h mm	N mm	P mm	dynamic C kN	static C _o kN	M _P M _{P2} N · m	M _V M _{V2} N · m	M _R N · m	block kg	guide rail kg/m	
5	pressed fitting	13.5	15	3.5 × 6 × 4.5	20	60	7.29	9.46	37	37	74	0.1	1.3	15
				4.5 × 7.5 × 5.3					252	252				
6	B-M6F	16	20	6 × 9.5 × 8.5	20	80	11.91	14.81	72	72	159	0.2	2.1	20
6.5		20	23	7 × 11 × 9					123	123				
									751	751				
9		24	28	9 × 14 × 12					195	195				
8.5	27.5	34	294		294	693	0.8	6.2	35					

1kN ≅ 102kgf 1N·m ≅ 0.102kgf·m

							maximum length mm
1,240	1,360	1,480					2,000
1,360	1,480	1,600	1,660	1,720	1,840	1,960	3,000
1,360	1,480	1,600	1,660	1,720	1,840	1,960	3,000
1,640	1,720	1,800	1,880	1,960			3,000
1,640	1,720	1,800	1,880	1,960			3,000

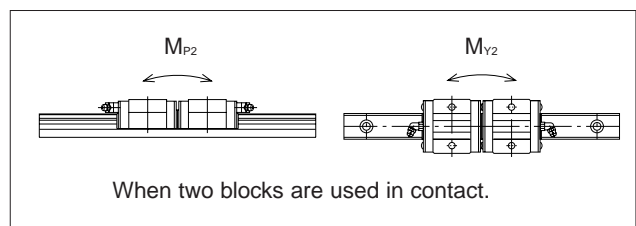

GL-TF TYPE

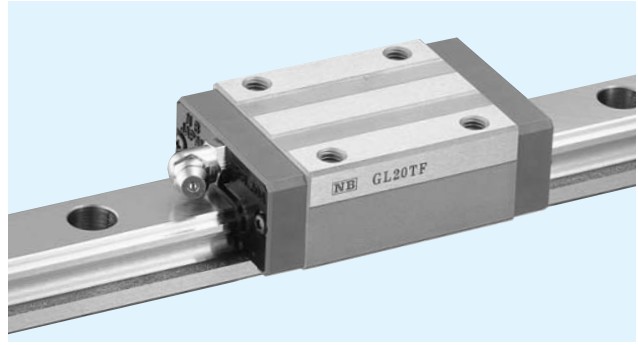

part number structure example **GL 15 F B 2 T1 - 589 D P / W2 RD F J KGL**

GL type
 size
 block style
 seal(refer to page A-14)

B(standard)	With side seals + under-seal
BW	With double seals + under-seal
BS	B + scraper

number of blocks per rail
 symbol for pre-load

blank	standard
T1	light
T2	medium

total length of rail
 size of rail installation hole(D type rail is available only for GL 15)
 accuracy grade

blank	standard
H	high
P	precision

symbol for grease

blank	standard grease w/fiber sheet
KGL	litum-based grease w/o fiber sheet
KGU	urea-based grease w/o fiber sheet
KGF	anti-fretting grease w/o fiber sheet
GK	K-grease w/o fiber sheet

refer to page Eng-20 for details on special grease
 Fiber sheet is omitted when special grease is specified.

with bellows(refer to page A-16)
 with rail mounting hole caps
 with Raydent treatment

symbol for number of rails

blank	single rail
W2	double rails
W3	triple rails

The symbol for the number of rails does not mean the number of rail ordered.

part number	assembly dimensions		block dimensions												
	H	W	B	L ₁	L ₂	L ₃	L ₄	P ₁	P ₂	S ₁	ℓ	T	b	E ₁	E ₂
	mm	mm	mm	mm	mm	mm	mm	mm	mm	mm	mm	mm	mm	mm	mm
GL15TF GL15TF-D	24	9.5	34	56.5	38.5	62.7	63.1	26	26	M4	7	6	19.5	5	5.4
GL20TF	28	11	42	65.8	47.4	72.0	72.4	32	32	M5	8	7.5	22	14	13.3
GL25TF	33	12.5	48	80	59	86.4	87.2	35	35	M6	9	8	26		13.1
GL30TF	42	16	60	95.7	67.7	104.3	103.3	40	40	M8	12	9	32.5		14
GL35TF	48	18	70	109	78	117.6	116.6	50	50			13	38		

part number	standard rail length															
	L mm															
GL15	160	220	280	340	400	460	520	580	640	700	760	820	880	940	1,000	1,120
GL20	220	280	340	400	460	520	580	640	700	760	820	880	940	1,000	1,120	1,240
GL25	220	280	340	400	460	520	580	640	700	760	820	880	940	1,000	1,120	1,240
GL30	280	360	440	520	600	680	760	840	920	1,000	1,080	1,160	1,240	1,320	1,400	1,480
GL35	280	360	440	520	600	680	760	840	920	1,000	1,080	1,160	1,240	1,320	1,400	1,480

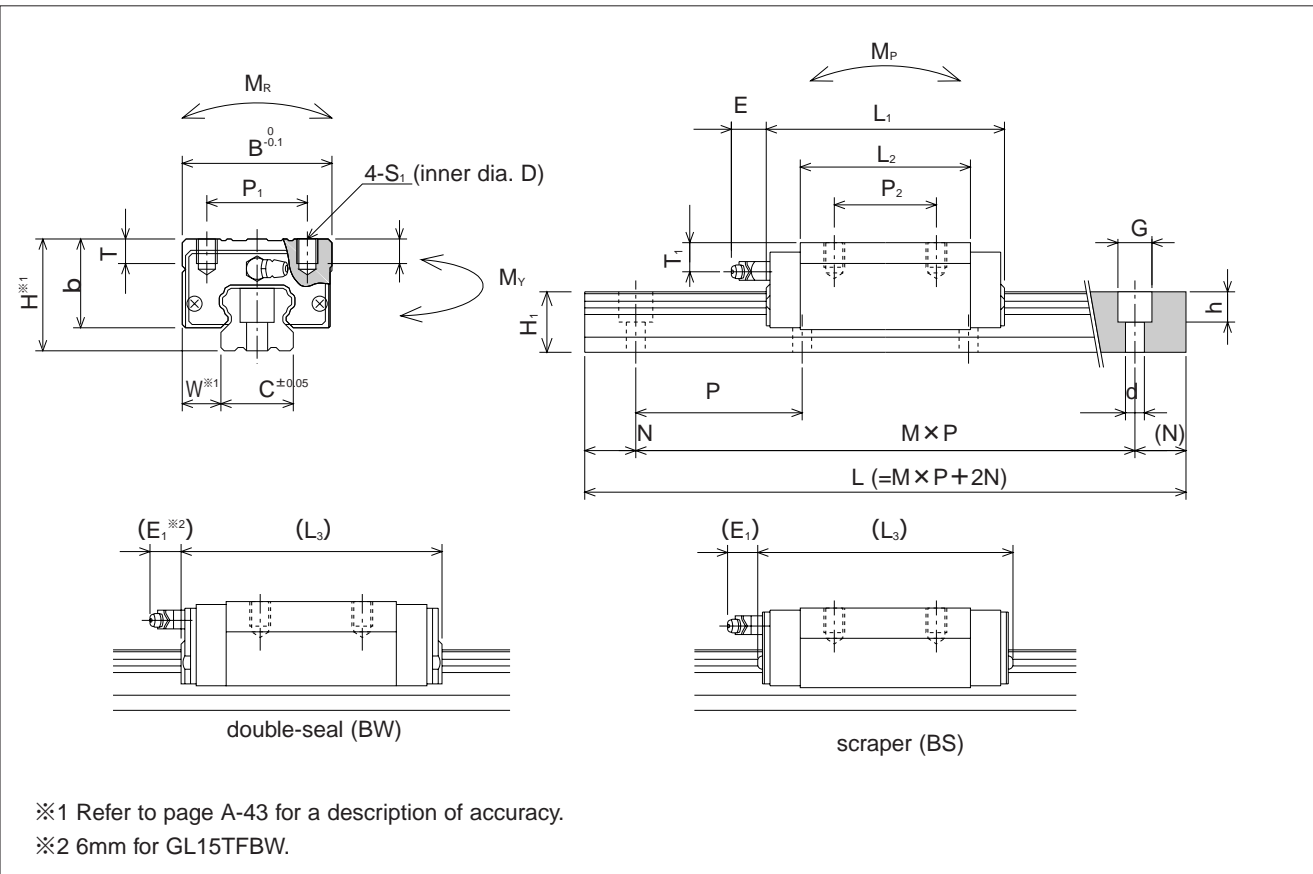

T ₁ mm	grease fitting	guide-rail dimensions					basic load rating		allowable static moment			mass		size		
		H ₁ mm	C mm	d × G × h mm	N mm	P mm	dynamic C kN	static C ₀ kN	M _P N · m	M _Y N · m	M _R N · m	block kg	guide rail kg/m			
5	pressed fitting	13.5	15	3.5 × 6 × 4.5	20	60	10.6	16.2	100	100	127	0.2	1.3	15		
				4.5 × 7.5 × 5.3												
6	B-M6F	16	20	6 × 9.5 × 8.5					16.4	23.3	165	165	250	0.3	2.1	20
6.5		20	23	7 × 11 × 9					24.8	36.3	335	335	437	0.4	3.0	25
9		24	28						33.6	49.2	529	529	716	0.8	4.6	30
8.5		27.5	34	9 × 14 × 12		80	46.7	64.8	796	796	1,188	1.3	6.2	35		

1kN ≒ 102kgf 1N·m ≒ 0.102kgf·m

							maximum length mm
1,240	1,360	1,480					2,000
1,360	1,480	1,600	1,660	1,720	1,840	1,960	3,000
1,360	1,480	1,600	1,660	1,720	1,840	1,960	3,000
1,640	1,720	1,800	1,880	1,960			3,000
1,640	1,720	1,800	1,880	1,960			3,000

GL-HTF TYPE

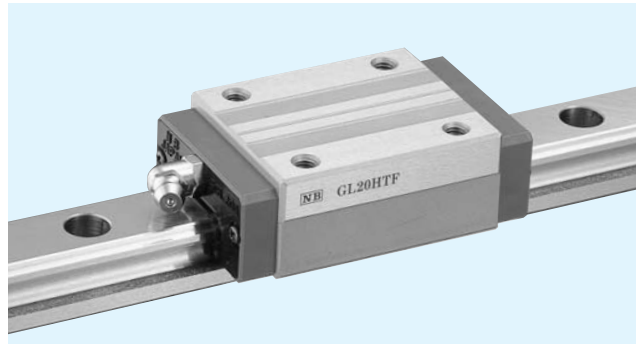

part number structure example **GL 20 HTF B 2 T1 - 589 P / W2 RD F J KGL**

GL type
size
block style
seal(refer to page A-14)

B(standard)	With side seals + under-seal
BW	With double seals + under-seal
BS	B + scraper

number of blocks per rail
symbol for pre-load

blank	standard
T1	light
T2	medium

total length of rail
accuracy grade

blank	standard
H	high
P	precision

symbol for grease

blank	standard grease w/fiber sheet
KGL	lithium-based grease w/o fiber sheet
KGU	urea-based grease w/o fiber sheet
KGF	anti-fretting grease w/o fiber sheet
GK	K-grease w/o fiber sheet

refer to page Eng-20 for details on special grease
Fiber sheet is omitted when special grease is specified.

with bellows(refer to page A-16)
with rail mounting hole caps
with Raydent treatment
symbol for number of rails

blank	single rail
W2	double rails
W3	triple rails

The symbol for the number of rails does not mean the number of rail ordered.

part number	assembly dimensions		block dimensions												
	H	W	B	L ₁	L ₂	L ₃	L ₄	P ₁	P ₂	S ₁	ℓ	T	b	E ₁	E ₂
	mm	mm	mm	mm	mm	mm	mm	mm	mm	mm	mm	mm	mm	mm	mm
GL15HTF	28	9.5	34	56.5	38.5	62.7	63.1	26	26	M4	5	6	23.7	5	5.4
GL20HTF	30	12	44	71.6	53.2	77.8	78.2	32	36	M5	6	9.5	24	14	13.3
GL25HTF	40	12.5	48	80	59	86.4	87.2	35	35	M6	8	9	33		13.1
GL30HTF	45	16	60	95.7	67.7	104.3	103.3	40	40	M8	10		35.5		14
GL35HTF	55	18	70	109	78	117.6	116.6	50	50			12	13	45	
GL45HTF	70	20.5	86	139	102	147.5	148	60	60	M10	17	15	60	16	16

part number	standard rail length															
	L mm															
GL15	160	220	280	340	400	460	520	580	640	700	760	820	880	940	1,000	1,120
GL20	220	280	340	400	460	520	580	640	700	760	820	880	940	1,000	1,120	1,240
GL25	220	280	340	400	460	520	580	640	700	760	820	880	940	1,000	1,120	1,240
GL30	280	360	440	520	600	680	760	840	920	1,000	1,080	1,160	1,240	1,320	1,400	1,480
GL35	280	360	440	520	600	680	760	840	920	1,000	1,080	1,160	1,240	1,320	1,400	1,480
GL45	570	675	780	885	990	1,095	1,200	1,305	1,410	1,515	1,620	1,725	1,830	1,935	2,040	2,145

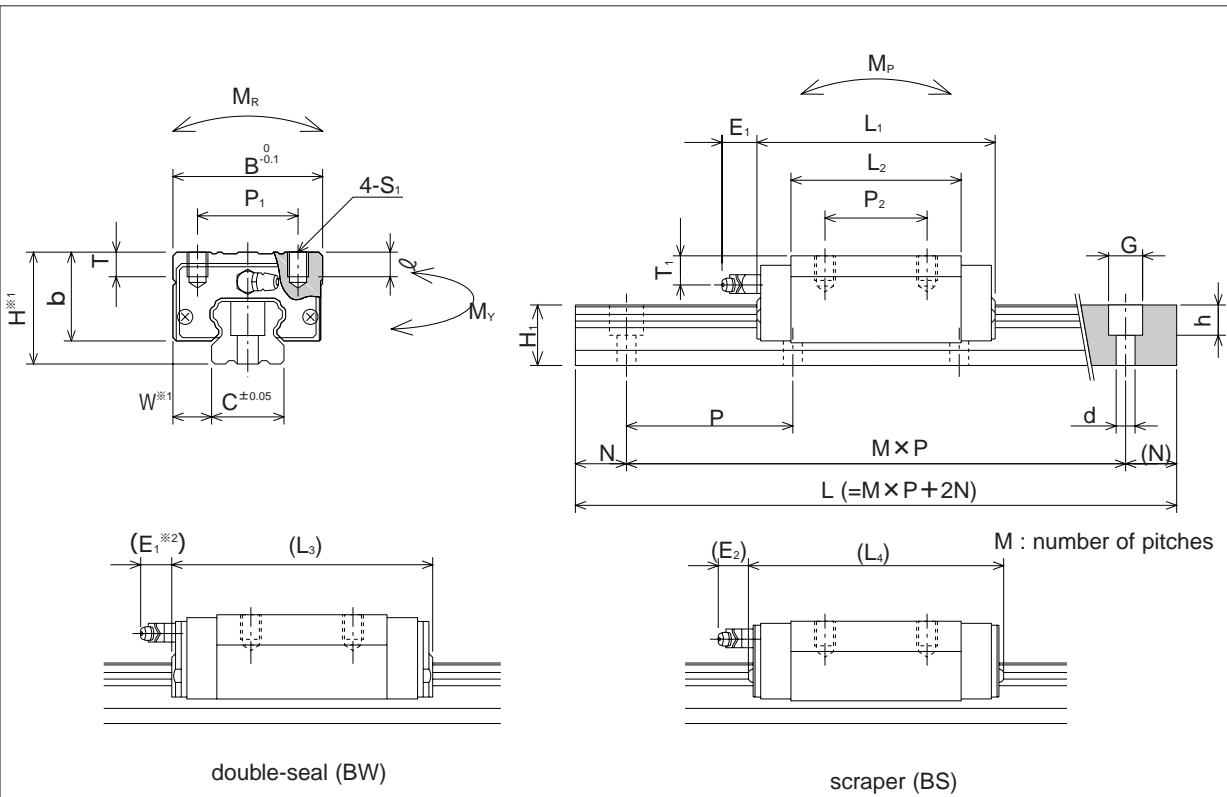

※1 Refer to page A-43 for a description of accuracy.
 ※2 6mm for GL15HTFBW.

T ₁ mm	grease fitting	guide-rail dimensions					basic load rating		allowable static moment			mass		size
		H ₁ mm	C mm	d × G × h mm	N mm	P mm	dynamic C kN	static C ₀ kN	M _P N · m	M _V N · m	M _R N · m	block kg	guide rail kg/m	
9	pressed fitting	13.5	15	4.5 × 7.5 × 5.3	20	60	10.6	16.2	100	100	127	0.2	1.3	15
8	B-M6F	16	20	6 × 9.5 × 8.5			18.4	27.5	227	227	296	0.4	2.1	20
13.5		20	23	7 × 11 × 9			24.8	36.3	345	345	437	0.6	3.0	25
12	24	28	9 × 14 × 12	80		33.6	49.2	529	529	716	0.9	4.6	30	
15.5	27.5	34				46.7	64.8	796	796	1,188	1.5	6.2	35	
20	B-PT1/8	36.5	45	14 × 20 × 17	22.5	105	74.8	101.2	1,553	1,553	2,312	3.1	10.5	45

1kN ≒ 102kgf 1N·m ≒ 0.102kgf·m

									maximum length mm
1,240	1,360	1,480							2,000
1,360	1,480	1,600	1,660	1,720	1,840	1,960	3,000		
1,360	1,480	1,600	1,660	1,720	1,840	1,960	3,000		
1,640	1,720	1,800	1,880	1,960					3,000
1,640	1,720	1,800	1,880	1,960					3,000
2,250	2,355	2,460	2,565	2,670	2,775	2,880	2,985	3,000	

GL-E TYPE

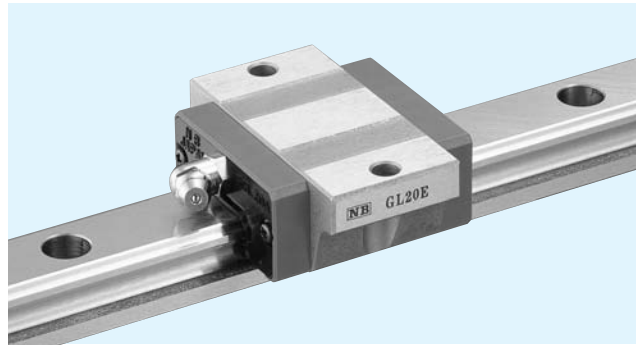

part number structure example **GL 15 E B 2 T1 - 589 D P / W2 RD F J KGL**

GL type

size

block style

seal(refer to page A-14)

B(standard)	With side seals + under-seal
BW	With double seals + under-seal
BS	B + scraper

number of blocks per rail

symbol for pre-load

blank	standard
T1	light
T2	medium

total length of rail

size of rail installation hole(D type rail is available only for GL 15)

accuracy grade

blank	standard
H	high
P	precision

symbol for grease

blank	standard grease w/fiber sheet
KGL	litum-based grease w/o fiber sheet
KGU	urea-based grease w/o fiber sheet
KGF	anti-fretting grease w/o fiber sheet
GK	K-grease w/o fiber sheet

refer to page Eng-20 for details on special grease
Fiber sheet is omitted when special grease is specified.

with bellows(refer to page A-16)

with rail mounting hole caps

with Raydent treatment

symbol for number of rails

blank	single rail
W2	double rails
W3	triple rails

The symbol for the number of rails does not mean the number of rail ordered.

part number	assembly dimensions		block dimensions										
	H	W	B	L ₁	L ₂	L ₃	L ₄	P ₁	S ₁	T	b	E ₁	E ₂
	mm	mm	mm	mm	mm	mm	mm	mm	mm	mm	mm	mm	mm
GL15E GL15E-D	24	18.5	52	40.7	22.7	46.9	47.3	41	4.5	7	19.5	5	5.4
GL20E	28	19.5	59	47.9	29.5	54.1	54.5	49	5.5	9	22	14	13.3
GL25E	33	25	73	58.7	37.7	65.1	65.9	60	7	10	26		13.1
GL30E	42	31	90	68	40	76.6	75.6	72	9	13	32.5		14
GL35E	48	33	100	77	46	85.6	84.6	82			38		

part number	standard rail length															
	L mm															
GL15	160	220	280	340	400	460	520	580	640	700	760	820	880	940	1,000	1,120
GL20	220	280	340	400	460	520	580	640	700	760	820	880	940	1,000	1,120	1,240
GL25	220	280	340	400	460	520	580	640	700	760	820	880	940	1,000	1,120	1,240
GL30	280	360	440	520	600	680	760	840	920	1,000	1,080	1,160	1,240	1,320	1,400	1,480
GL35	280	360	440	520	600	680	760	840	920	1,000	1,080	1,160	1,240	1,320	1,400	1,480

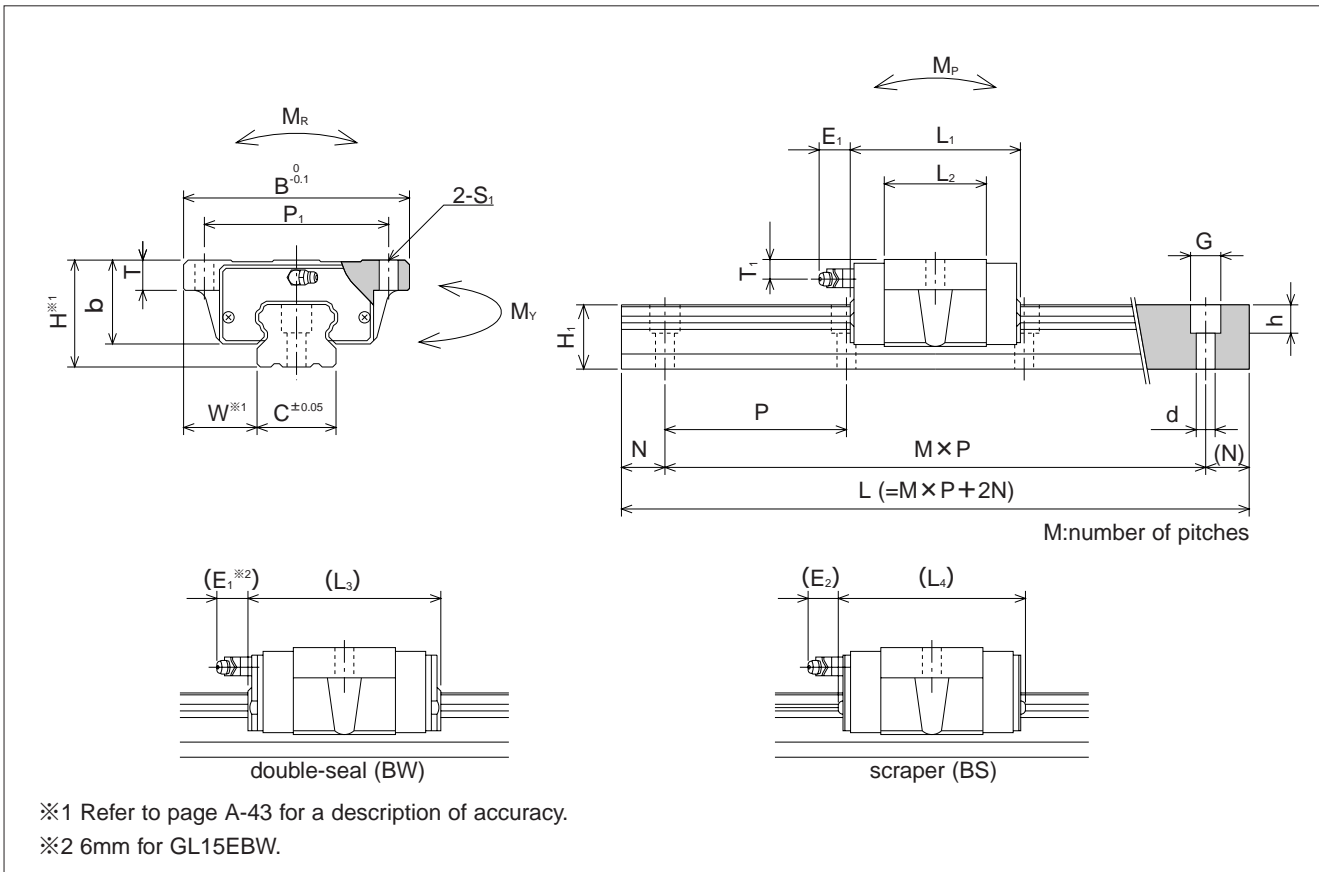

T ₁ mm	grease fitting	guide-rail dimensions					basic load rating		allowable static moment			mass		size
		H ₁ mm	C mm	d × G × h mm	N mm	P mm	dynamic C kN	static C ₀ kN	M _P M _{P2} N · m	M _Y M _{Y2} N · m	M _R N · m	block kg	guide rail kg/m	
5	pressed fitting	13.5	15	3.5 × 6 × 4.5	20	60	7.29	9.46	37	37	74	0.1	1.3	15
				4.5 × 7.5 × 5.3					252	252				
6	B-M6F	16	20	6 × 9.5 × 8.5	20	60	11.91	14.81	72	72	159	0.2	2.1	20
6.5		23	7 × 11 × 9	123					123					
9		24		28	80	195	195	418	0.6	4.6	30			
8.5		27.5	34	9 × 14 × 12		1,263	1,263							
					294	294	693	0.9	6.2	35				
												1,873	1,873	

$$1 \text{ kN} \doteq 102 \text{ kgf} \quad 1 \text{ N} \cdot \text{m} \doteq 0.102 \text{ kgf} \cdot \text{m}$$

							maximum length mm
1,240	1,360	1,480					2,000
1,360	1,480	1,600	1,660	1,720	1,840	1,960	3,000
1,360	1,480	1,600	1,660	1,720	1,840	1,960	3,000
1,640	1,720	1,800	1,880	1,960			3,000
1,640	1,720	1,800	1,880	1,960			3,000

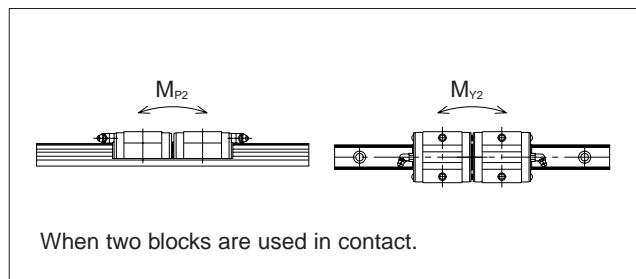

GL-TE TYPE

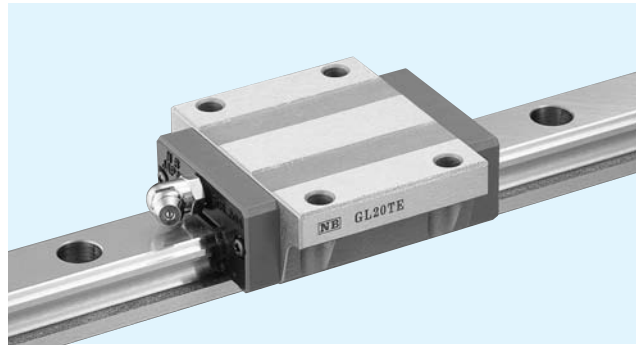

part number structure example **GL 15 TE B 2 T1 - 589 D P / W2 RD F J KGL**

GL type

size

block style

seal(refer to page A-14)

B(standard)	With side seals + under-seal
BW	With double seals + under-seal
BS	B + scraper

number of blocks per rail

symbol for pre-load

blank	standard
T1	light
T2	medium

total length of rail

size of rail installation hole(D type rail is available only for GL 15)

accuracy grade

blank	standard
H	high
P	precision

symbol for grease

blank	standard grease w/fiber sheet
KGL	litum-based grease w/o fiber sheet
KGU	urea-based grease w/o fiber sheet
KGF	anti-fretting grease w/o fiber sheet
GK	K-grease w/o fiber sheet

refer to page Eng-20 for details on special grease
Fiber sheet is omitted when special grease is specified.

with bellows(refer to page A-16)

with rail mounting hole caps

with Raydent treatment

symbol for number of rails

blank	single rail
W2	double rails
W3	triple rails

The symbol for the number of rails does not mean the number of rail ordered.

part number	assembly dimensions		block dimensions											
	H	W	B	L ₁	L ₂	L ₃	L ₄	P ₁	P ₂	S ₁	T	b	E ₁	E ₂
	mm	mm	mm	mm	mm	mm	mm	mm	mm	mm	mm	mm	mm	mm
GL15TE GL15TE-D	24	18.5	52	56.5	38.5	62.7	63.1	41	26	4.5	7	19.5	5	5.4
GL20TE	28	19.5	59	65.8	47.4	72.0	72.4	49	32	5.5	9	22	14	13.3
GL25TE	33	25	73	80	59	86.4	87.2	60	35	7	10	26		13.1
GL30TE	42	31	90	95.7	67.7	104.3	103.3	72	40	9	13	32.5	14	
GL35TE	48	33	100	109	78	117.6	116.6	82	50			38		

part number	standard rail length															
	L mm															
GL15	160	220	280	340	400	460	520	580	640	700	760	820	880	940	1,000	1,120
GL20	220	280	340	400	460	520	580	640	700	760	820	880	940	1,000	1,120	1,240
GL25	220	280	340	400	460	520	580	640	700	760	820	880	940	1,000	1,120	1,240
GL30	280	360	440	520	600	680	760	840	920	1,000	1,080	1,160	1,240	1,320	1,400	1,480
GL35	280	360	440	520	600	680	760	840	920	1,000	1,080	1,160	1,240	1,320	1,400	1,480

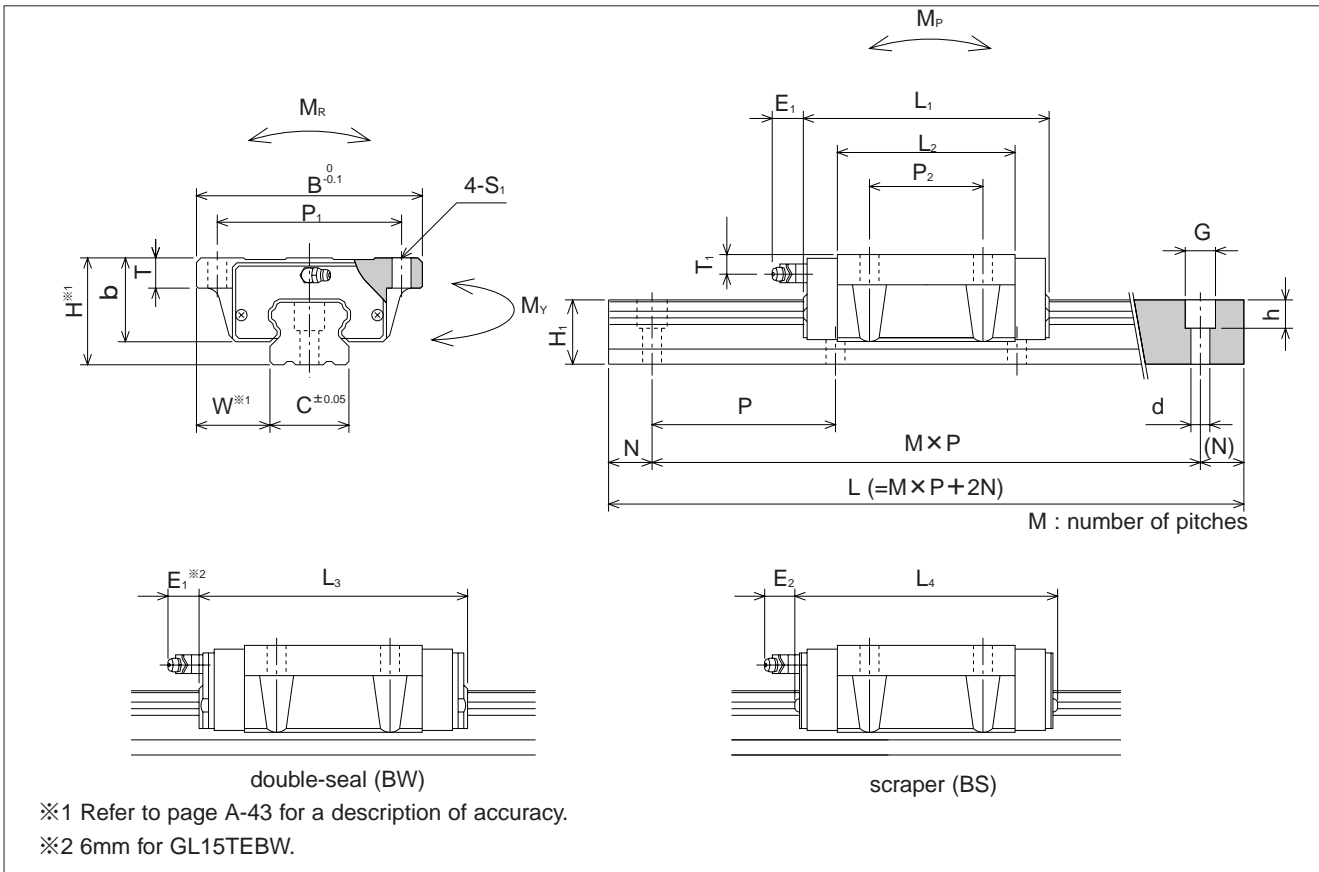

T ₁ mm	grease fitting	guide-rail dimensions					basic load rating		allowable static moment			mass		size
		H ₁ mm	C mm	d × G × h mm	N mm	P mm	dynamic C kN	static CO kN	M _P N · m	M _V N · m	M _R N · m	block kg	guide rail kg/m	
5	pressed fitting	13.5	15	3.5 × 6 × 4.5	20	60	10.6	16.2	100	100	127	0.2	1.3	15
				4.5 × 7.5 × 5.3										
6	B-M6F	16	20	6 × 9.5 × 8.5										
6.5		20	23	7 × 11 × 9										
9		24	28											
8.5		27.5	34	9 × 14 × 12	80	46.7	64.8	796	796	1,188	1.5	6.2	35	

1kN ≒ 102kgf 1N · m ≒ 0.102kgf · m

								maximum length mm
1,240	1,360	1,480						2,000
1,360	1,480	1,600	1,660	1,720	1,840	1,960	3,000	
1,360	1,480	1,600	1,660	1,720	1,840	1,960	3,000	
1,640	1,720	1,800	1,880	1,960				3,000
1,640	1,720	1,800	1,880	1,960				3,000

GL-HTE TYPE

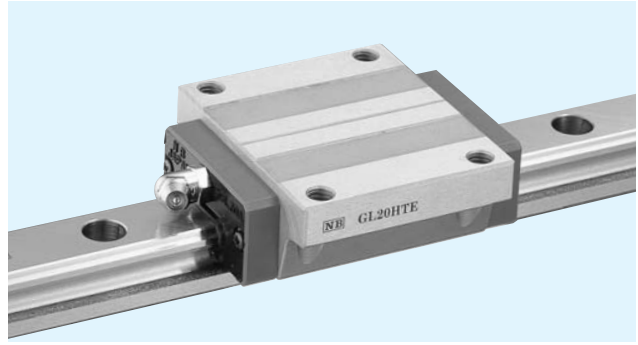

part number structure example **GL 20 HTE B 2 T1 - 589 P / W2 RD F J KGL**

GL type
 size
 block style
 seal(refer to page A-14)

B(standard)	With side seals + under-seal
BW	With double seals + under-seal
BS	B + scraper

number of blocks per rail
 symbol for pre-load

blank	standard
T1	light
T2	medium

total length of rail
 size of rail installation hole
 accuracy grade

blank	standard
H	high
P	precision

symbol for grease

blank	standard grease w/fiber sheet
KGL	litium-based grease w/o fiber sheet
KGU	urea-based grease w/o fiber sheet
KGF	anti-fretting grease w/o fiber sheet
GK	K-grease w/o fiber sheet

refer to page Eng-20 for details on special grease
 Fiber sheet is omitted when special grease is specified.

with bellows(refer to page A-16)
 with rail mounting hole caps
 with Raydent treatment

symbol for number of rails

blank	single rail
W2	double rails
W3	triple rails

The symbol for number of rails does not mean the number of rail ordered.

part number	assembly dimensions		block dimensions												
	H	W	B	L ₁	L ₂	L ₃	L ₄	P ₁	P ₂	S ₁	D	T	b	E ₁	E ₂
	mm	mm	mm	mm	mm	mm	mm	mm	mm	mm	mm	mm	mm	mm	mm
GL15HTE	24	16	47	56.5	38.5	62.7	63.1	38	30	M5	4.4	7.5	19.7	5	5.4
GL20HTE	30	21.5	63	71.6	53.2	77.8	78.2	53	40	M6	5.4	10.5	24	14	13.3
GL25HTE	36	23.5	70	80	59	86.4	87.2	57	45	M8	6.8	12.5	29		13.1
GL30HTE	42	31	90	95.7	67.7	104.3	103.3	72	52	M10	8.5	10	32.5		14
GL35HTE	48	33	100	109	78	117.6	116.6	82	62			13	38	14	
GL45HTE	60	37.5	120	139	102	147.5	148	100	80	M12	10.5	15	50	16	16

part number	standard rail length															
	L mm															
GL15	160	220	280	340	400	460	520	580	640	700	760	820	880	940	1,000	1,120
GL20	220	280	340	400	460	520	580	640	700	760	820	880	940	1,000	1,120	1,240
GL25	220	280	340	400	460	520	580	640	700	760	820	880	940	1,000	1,120	1,240
GL30	280	360	440	520	600	680	760	840	920	1,000	1,080	1,160	1,240	1,320	1,400	1,480
GL35	280	360	440	520	600	680	760	840	920	1,000	1,080	1,160	1,240	1,320	1,400	1,480
GL45	570	675	780	885	990	1,095	1,200	1,305	1,410	1,515	1,620	1,725	1,830	1,935	2,040	2,145

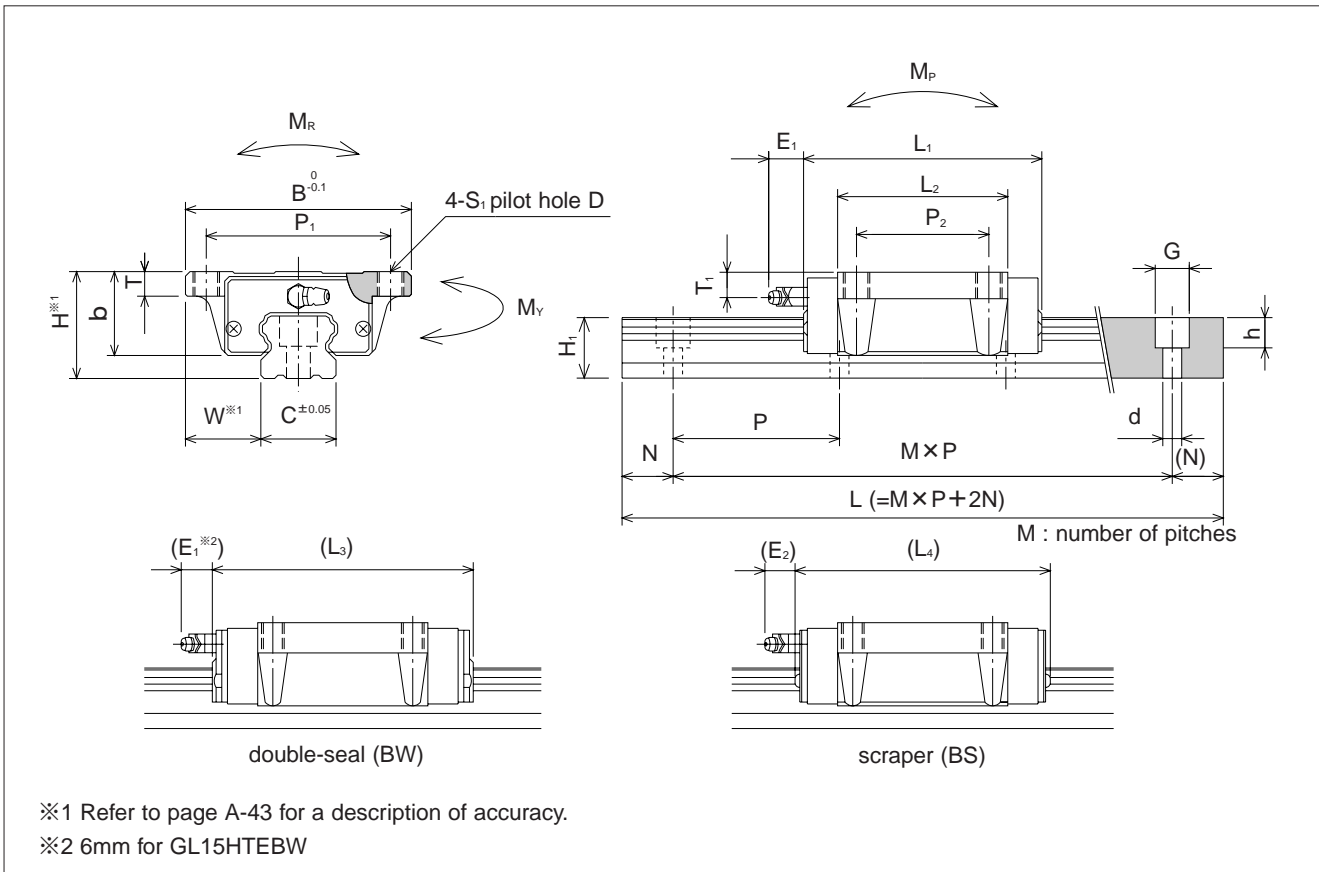

T ₁ mm	grease fitting	guide-rail dimensions					basic load rating		allowable static moment			mass		size
		H ₁ mm	C mm	d × G × h mm	N mm	P mm	dynamic C kN	static C ₀ kN	M _P N · m	M _Y N · m	M _R N · m	block kg	guide rail kg/m	
5	pressed fitting	13.5	15	4.5 × 7.5 × 5.3	20	60	10.6	16.2	100	100	127	0.2	1.3	15
8	B-M6F	16	20	6 × 9.5 × 8.5			18.4	27.5	227	227	296	0.4	2.1	20
9.5		20	23	7 × 11 × 9			24.8	36.3	335	335	437	0.6	3.0	25
9	B-M6F	24	28	9 × 14 × 12		80	33.6	49.2	529	529	716	1.0	4.6	30
8.5		27.5	34				46.7	64.8	796	796	1,188	1.5	6.2	35
10	B-PT1/8	36.5	45	14 × 20 × 17	22.5	105	74.8	101.2	1,553	1,553	2,312	3.1	10.5	45

	maximum length mm
1,240 1,360 1,480	2,000
1,360 1,480 1,600 1,660 1,720 1,840 1,960	3,000
1,360 1,480 1,600 1,660 1,720 1,840 1,960	3,000
1,640 1,720 1,800 1,880 1,960	3,000
1,640 1,720 1,800 1,880 1,960	3,000
2,250 2,355 2,460 2,565 2,670 2,775 2,880 2,985	3,000