



NEW PRODUCT

SLIDE BUSH

New Generation

GW type



Certificate No.958188



NIPPON BEARING CO., LTD.

New Generation of NB Slide Bush GW type

NB's GW Slide Bush series features an outer cylinder "load section" made of hardened steel and a "ball return section" made of resin. The two sections are formed together as one unit resulting in an overall weight reduction of 30~50% when compared to our traditional SW Slide Bush, while maintaining equivalent accuracies and capacities. This new generation Slide Bush will respond to the demands of "low-cost" as well as broaden the application scope of Slide Bush.

STRUCTURE AND FEATURES

NB's GW Slide Bush consists of an outer cylinder casing, steel balls, and ball retainer. The outer cylinder casing is steel combined with resin and is formed by precision grinding processes.

Light weight

The GW Slide Bush makes efficient use of resin components making it possible to achieve an overall weight reduction of 30~50% when compared with the SW Slide Bush.

Low Noise Design

The ball return section is configured completely in resin material, which provides for low noise operation.

Smooth Movement, High Acceleration/Deceleration Support

The GW Slide Bush provides smooth movement under high acceleration/deceleration motion through the accurately lined-up circulation of the balls and the light weight structure.

Seal

An optional integral resin seal is also available.

Figure 1: Structure of GW Slide Bush

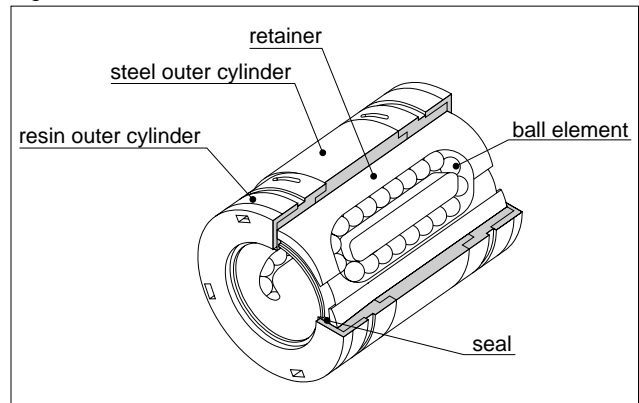

INSTALLATION

Table 1: Recommended Fit

series	accuracy grade	shaft		housing
		clearance fit	transition fit	clearance fit
GW	High	g6	h6	H7

Installation Notes

When inserting the GW Slide Bush into a housing, apply an even force to the end of the outer cylinder using a jig such as shown in Figure 2. Handle careful as a precision component; do not subject to strong shocks by dropping or hammering on the resin outer cylinder.

When using two or more shafts, it is very important to maintain the parallelism between shafts, as this will greatly affect the smoothness of movement and component life. Adjust the parallelism as needed to achieve smooth movement during the operation of a GW Slide Bush.

Figure 2: Recommended Installation Method

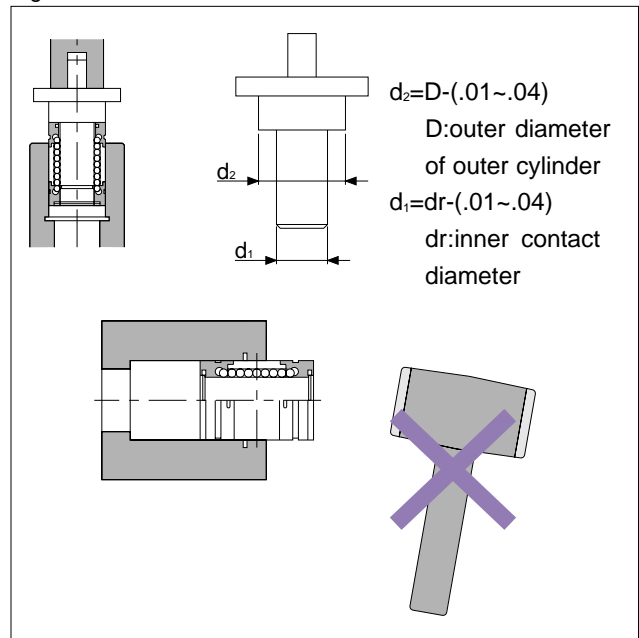

GW TYPE

– Light Weight Type –

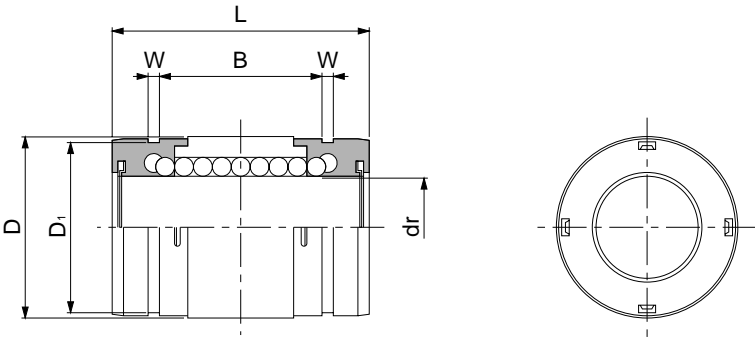
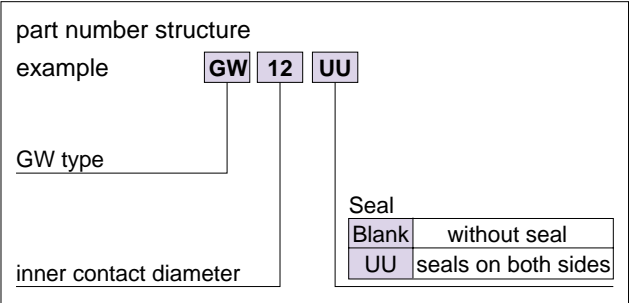

part number	number of ball circuits	major dimensions								basic load rating		mass
		dr		D		L	B	W	D ₁	dynamic	static	
		inch	tolerance inch	inch	tolerance inch	inch	inch	inch	inch	C N	Co N	
GW 4	4	.2500	0 - .00040	.5000	0/- .00045	.7500	.4329	.0390	.4687	206	265	5.4
GW 6	4	.3750		.6250	0 - .00050	.8750	.5577	.0390	.5880	225	314	7.8
GW 8	4	.5000		.8750		1.2500	.8710	.0459	.8209	510	784	26
GW 10	4	.6250		1.1250	0 - .00065	1.5000	.9920	.0559	1.0590	774	1,180	51
GW 12	6	.7500		1.2500		1.6250	1.0538	.0559	1.1760	862	1,370	72
GW 16	6	1.0000		1.5625		2.2500	1.6187	.0679	1.4687	980	1,570	138
GW 20	6	1.2500		0/- .00050	2.0000	0/- .00075	2.6250	1.8687	.0679	1.8859	1,570	2,740

1N ≅ 0.225lbs 1kg ≅ 2.205lbs



NIPPON BEARING CO., LTD.

2833 Chiya, Ojiya-city, Niigata-pref., 947-8503 JAPAN
Phone: 81-258-82-0011 Fax: 81-258-81-1135
<http://www.nb-linear.co.jp>

NB Corporation of America

939 A.E.C. Drive, Wood Dale, IL 60191
Phone: (630) 227-1112 Fax: (630) 227-1118
Toll Free: (800) 521-2045

Western Regional Office

1214 Alderwood Ave., Sunnyvale, CA 94089
Phone: (408) 747-5000 Fax: (408) 747-5100
Toll Free: (888) 562-4175

Eastern Regional Office

52 First Street, Hackensack, NJ 07601
Phone: (201) 487-1441 Fax: (201) 487-7107
Toll Free: (800) 981-8190

<http://www.nbcorporation.com>
info@nbcorporation.com

Local Sales Representative:

--

No. 2540

First Edition: July 1, 2002