

**SLIDE  
WAY**

**SLIDE  
TABLE**

**MINIATURE  
SLIDE**

**GONIO  
WAY**

SLIDE GUIDE

BALL SPLINE  
ROTARY BALL SPLINE  
STROKE BALL SPLINE

TOPBALL® PRODUCTS

SLIDE BUSH

SLIDE UNIT

STROKE BUSH  
SLIDE ROTARY BUSH

SLIDE SHAFT

SLIDE WAY/GONIO WAY  
SLIDE TABLE  
MINIATURE SLIDE

ACTUATOR

SLIDE SCREW

# SLIDE WAY

STUDROLLER system  
NV type/NVT type

NB' s Slide Way NV and NVT types incorporate STUDROLLER, which has been developed based upon a new concept. By completely eliminating slippage between the roller and track surfaces, these new Slide Ways possess the smoothest and most accurate linear movement in the world.

## STRUCTURE AND ADVANTAGES

NB' s Slide Way NV and NVT types consist of precisely ground tracking bases and R-retainers with built-in stud-rollers. To smooth the STUDROLLER, the tracking rail is optimally designed and the R-retainer incorporates the STUDROLLER and the precise roller. These ideas will enable slip-free operation between the raceway surface and the roller, resulting in motion with minimal frictional resistance.

### Non-slip STUDROLLER System

The built-in STUDROLLER system, based on the new concept, completely eliminates slip inside the product, covering various applications including super-high acceleration/deceleration applications.

### Compatibility with conventional types

The same dimensions and the same stroke as the Slide Way SV type enable complete compatibility between the two series.

### Smooth movement

The optimally designed roller raceway section and the R-retainer ensure smooth, noiseless movement.

### Space and Cost Saving

Increased load capacity allows for down-sizing and lowering costs of the component, thus enabling space and cost saving. (comparing with conventional SV type.)

### High rigidity and high-loading capacity

Based on the new tracking base design, the contact length of the roller and the raceway surface is increased by 42 to 58%, and narrowing the roller pitch increases the number of roller units to be connected. Accordingly, the load rating is 1.4 to 2.3 times greater when compared to the conventional SV type.

Figure H-1 detailed roller contact image

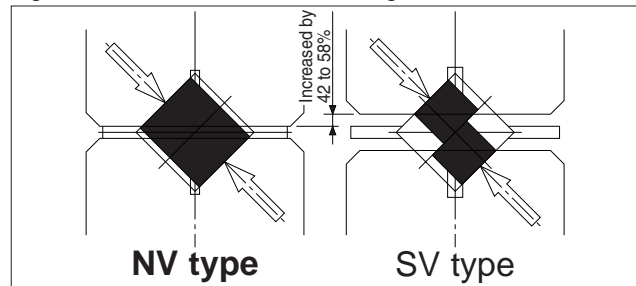

Figure H-2 STUDROLLER system

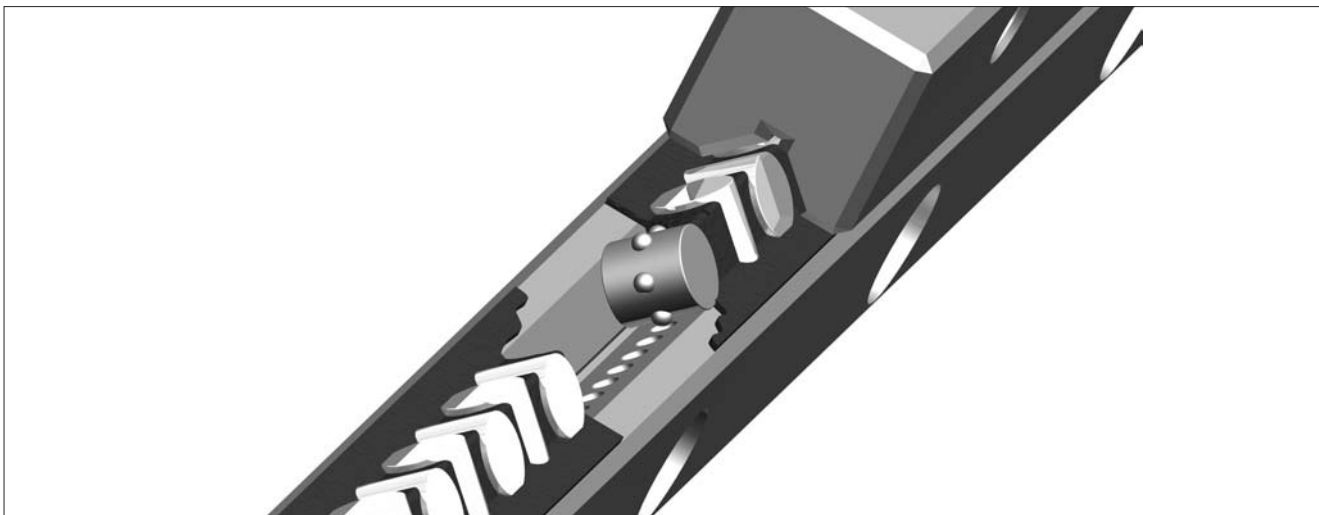

Figure H-3 Structure of NV type

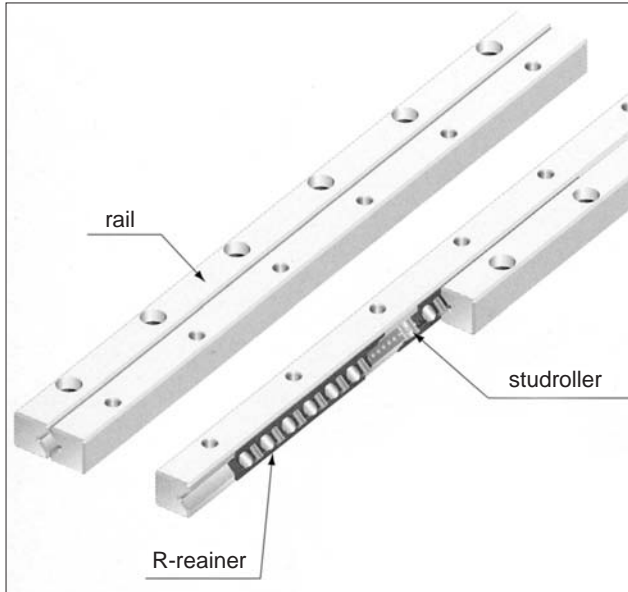
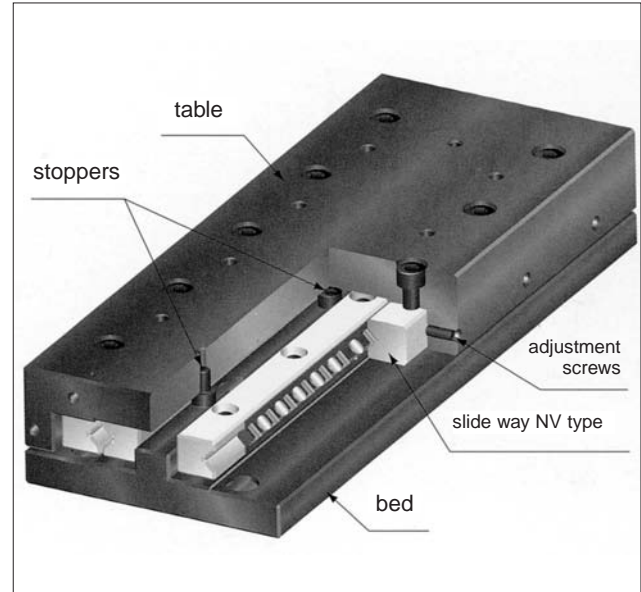
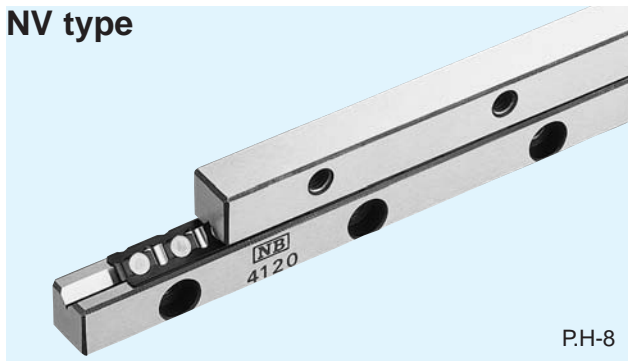

Figure H-4 Structure of NVT type



## TYPE

### NV type



### NV type

This consists of a set of four track rails and two R-retainers. Flexible table design allows for a wide range of applications best suited to your purpose.

### NVT type

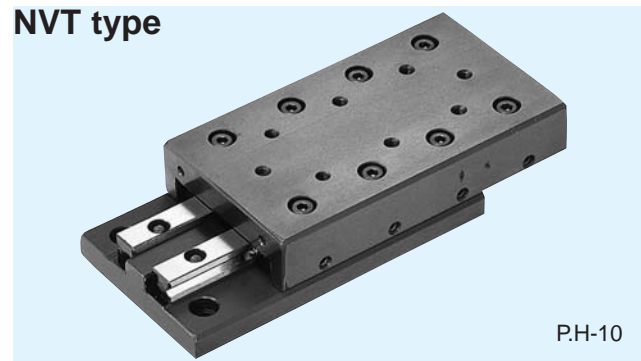

### NVT type

A slide table incorporates the NV type. The precisely machined table and bed ensure great accuracy. This table may be used as received without any troublesome accuracy or preload adjustments.

# ACCURACY

## NV type

The accuracy of the Slide Way NV type is represented as parallelism obtained from full-length measurement as shown in Figure H-5. It is classified into three grades: High (no symbol), Precision (P) and Ultra Precision (UP). The Slide Way NV type is available for special accuracy. Please contact NB for details.

Figure H-5, Parallelism

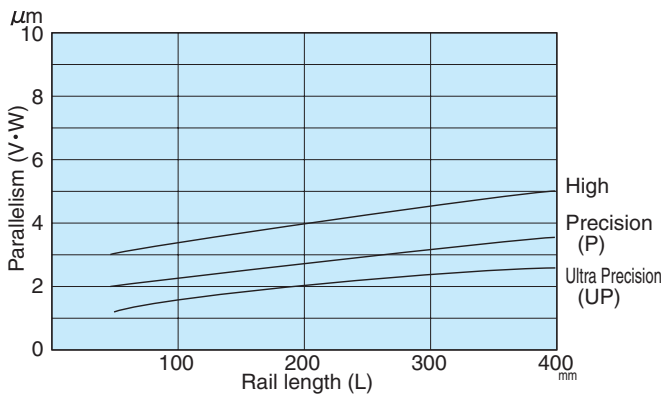

## NVT type

The motion accuracy of the slide table NVT type is represented as deviation on the dial indicators attached to the center of the top and side of the table, when the table runs full stroke without load.

Figure H-6, Accuracy Measurement

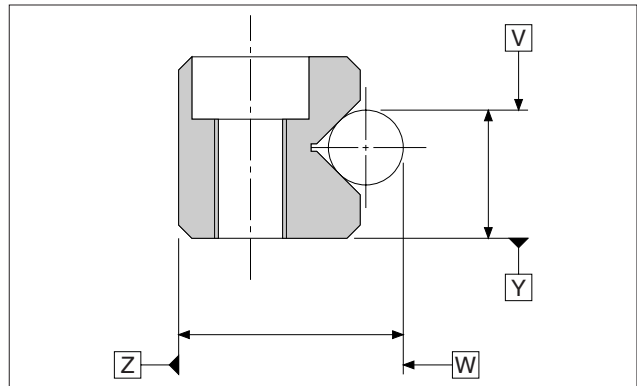
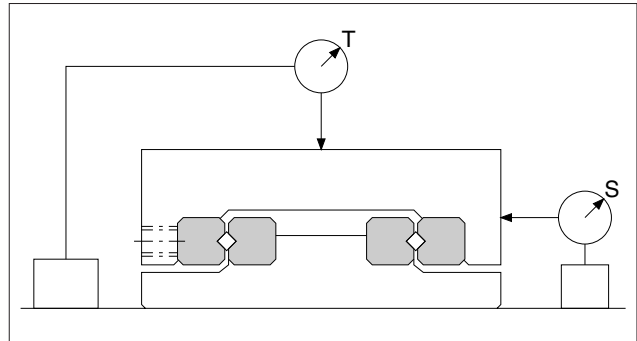

Figure H-7, Accuracy Measurement



## LOAD RATING

The load rating of the Slide Way NV and NVT type varies depending on the direction of load.

Table H-1 Load Rating

Basic dynamic load rating	Normal vertical direction	$1.0 \times C$
	Horizontal direction	$0.9 \times C$
	Reverse vertical direction	$0.8 \times C$
Basic static load rating	Normal vertical direction	$1.0 \times C_0$
	Horizontal direction	$0.9 \times C_0$
	Reverse vertical direction	$0.8 \times C_0$

※The load rating ratio above may be different for particular sizes. Please contact NB for further details.

Figure H-8 Direction of Load

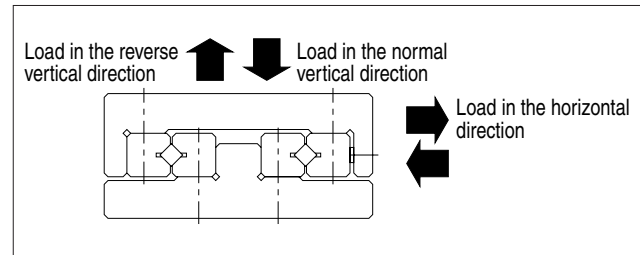

## RATED LIFE

The life of the Slide Way and Slide Table are calculated using the following equation:

Rated life

$$L = \left( \frac{1}{f_w} \cdot \frac{C}{P} \right)^{10/3} \cdot 50$$

L: rated life,  $f_w$ : load coefficient, C: basic dynamic load rating (N), P: load (N).  
 ※For each coefficient, please refer to page Eng.-5

Life Time

$$L_h = \frac{L \cdot 10^3}{2 \cdot \ell_s \cdot n_1 \cdot 60}$$

$L_h$ : life time (hours),  $\ell_s$ : stroke (m),  $n_1$ : number of cycles per minute (cpm)

# MOUNTING NV TYPE

## Accuracy of mounting surface

To maximize the performance of the NB Slide Way, it is recommended that accuracy of the mounting surface should be finished to be equal to or greater than the parallelism level of the Slide Way.

- Parallelism of surface 1 against surface A
- Perpendicularity of surface 2 against surface A
- Parallelism of surface 3 against surface B
- Perpendicularity of surface 4 against surface B
- Parallelism of surface 2 against surface C
- Parallelism of surface 4 against surface C

## Installation Procedure

- (1) Remove burrs, stains, and dust from the surface of the track rail of tables and beds to prevent contamination during assembly.
- (2) Apply low-viscosity oil to contact surfaces, and attach the tables to the beds (Figure H-11a).
- (3) Set the reference surface shown in Figure H-6 onto the mounting surface with the track rail assembled. Tighten adjusting screws lightly so that almost no gap is left while the table is set in the center (Figure H-11b).
- (4) Keep table in the center, tighten track rail mounting bolts lightly and peel the connection seal from both edges.
- (5) While maintaining the conditions in (4), tighten the adjusting screw on the R-retainer with the recommended torque shown in Table H-2 (Figure H-11c).
- (6) Move the table to one stroke end gently then, tighten the adjusting screw on the R-retainer in the same manner as in (5) (Figure H-11d).
- (7) Move the table to the opposite stroke end and tighten the adjusting screw in the same manner as in (5) (Figure H-11e).
- (8) Tighten the mounting bolts on track rail 1, 2 and 3 with the recommended torque shown in Table H-3 (Figure H-11f).
- (9) Set the dial indicators to the top and the side of the reference surface of the table (Figure H-11g).
- (10) Make final adjust of pre-load. Repeat steps (5) to (7) until the indicator will show a minimum deviation.
- (11) Finally, tighten the bolt on track rail ④ with the recommended torque. Be sure to tighten the mounting bolts on the R retainer sequentially while moving the table as when tightening the adjusting screws.

Table H-2 Recommended Torque for Adjusting Screw Unit/N•m

Part number	Size of screws	Torque
NV3	M4	0.05
NV4	M4	0.08
NV6	M5	0.20

Table H-3 Recommended Torque for Mounting Bolts Unit/N•m

Size of screws	Torque
M3	1.4
M4	3.2
M5	6.6
M6	11.2

Figure H-9 Accuracy of Mounting Surface

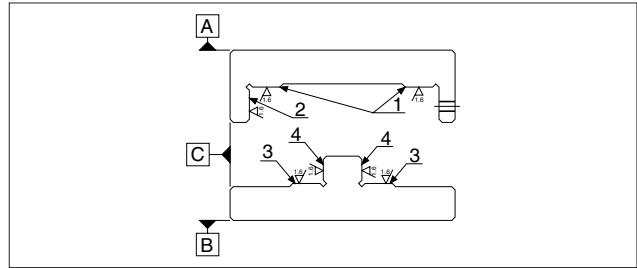

Figure H-10 Example of Mounting

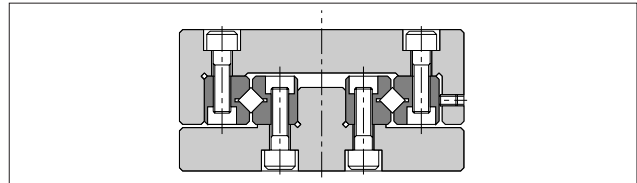
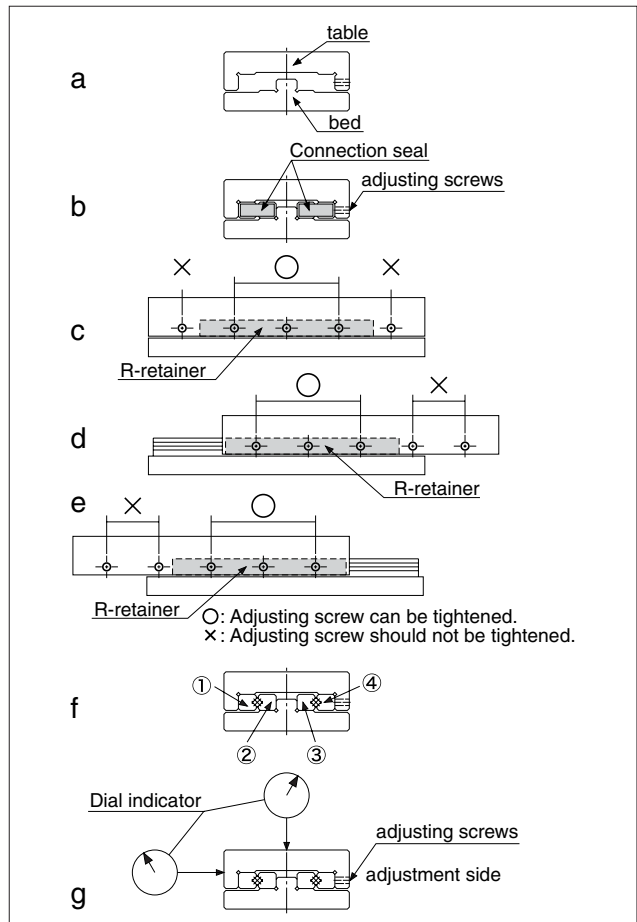

Figure H-11 Installation Method



## SPECIAL MOUNTING BOLT BT TYPE

To install the Slide Way using its counter bore, use of the special mounting bolt BT type is recommended.

Table H-4 Special Mounting Bolt

Part number	B	d mm	D mm	H mm	L <sub>1</sub> mm	L <sub>2</sub> mm	S mm	Applicable track rail
<b>BT 3</b>	M3	2.3	5	3	12	5	2.5	<b>NV 3</b>
<b>BT 4</b>	M4	3.1	5.8	4	15	7	3	<b>NV 4</b>
<b>BT 6</b>	M5	3.9	8	5	20	8	4	<b>NV 6</b>

Figure H-12 Special Mounting Bolt

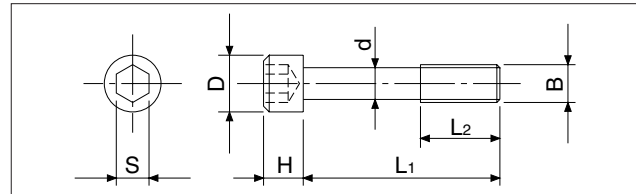

## LUBRICATION AND DUST PREVENTION

### Lubrication

The NB Slide Way is pre-lubricated using lithium soap-based grease prior to shipment and is therefore ready for immediate use. Make sure to lubricate with a similar type of grease periodically according to the operating conditions.

NB also provides grease for low-dust linear systems. Please refer to page Eng-20 for further details.

### Dust prevention

When dust and dirt enter the NB Slide Way, the accuracy and operating life may deteriorate. It is advisable to install an additional protective cover to protect the unit in a harsh environment (Figure H-13).

Figure H-13 Example of Dust Prevention Mechanism

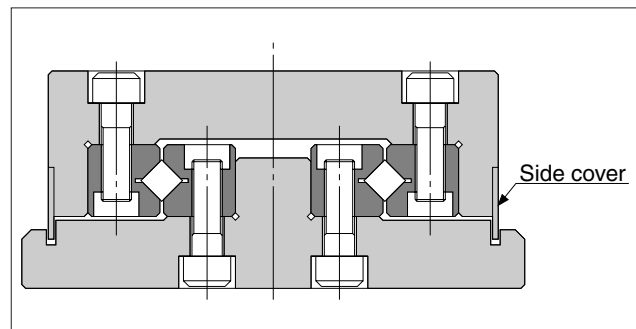

## PRECAUTIONS FOR USE

### Careful handling

NV type is packaged with the track rail and R retainer in one piece. Do not separate or disassemble these components until installation/assembly is completed. Dropping the NB Slide Way may cause the rolling elements to make dents on the raceway surface. This will prevent smooth motion and will also affect accuracy. Make sure to handle the product with care.

### Stopper

Over-stroke may cause the raceway surface of the track rail to be damaged and the performance of the STUDROLLER to drastically deteriorate. Be sure to provide an external mechanical stopper and use the product within the maximum allowable stroke.

### Adjustment

Using the product without mounting surface accuracy or before adjusting the pre-load will affect the life and

motion accuracy of the product. Make sure to install and adjust the product with care.

### Operating temperature

NV type contains resin parts. When using the product in high-temperature environments, the temperature must be lower than 80°C.

### Use as a set

The mutual accuracy in the track rails is adjusted within a particular set. Note that the accuracy may be affected when the track rails of different sets are used together in combination.

### Adjusting screws

Accuracy and pre-load of the Slide Table NVT type is factory-adjusted to the optimal level. Do not touch adjusting screws and mounting screws.

# NV TYPE

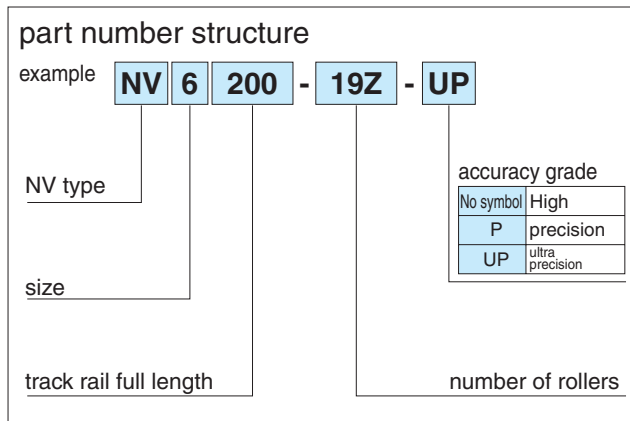

part number	stroke ST mm	roller diameter D mm	number of rollers Z	L	A	B	C	M×P
				mm	mm	mm	mm	mm
<b>NV3050- 9Z</b>	25	3	9	50	18	8	8.65	1×25
<b>NV3075-13Z</b>	48		13	75				2×25
<b>NV3100-19Z</b>	60		19	100				3×25
<b>NV3125-23Z</b>	83		23	125				4×25
<b>NV3150-29Z</b>	90		29	150				5×25
<b>NV3175-35Z</b>	103		35	175				6×25
<b>NV3200-41Z</b>	113		41	200				7×25
<b>NV4080- 9Z</b>	60	4	9	80	22	11	10.65	1×40
<b>NV4120-17Z</b>	75		17	120				2×40
<b>NV4160-23Z</b>	105		23	160				3×40
<b>NV4200-29Z</b>	130		29	200				4×40
<b>NV4240-37Z</b>	143		37	240				5×40
<b>NV6100- 9Z</b>	63	6	9	100	31	15	15.15	1×50
<b>NV6150-15Z</b>	85		15	150				2×50
<b>NV6200-19Z</b>	135		19	200				3×50
<b>NV6250-25Z</b>	158		25	250				4×50
<b>NV6300-31Z</b>	180		31	300				5×50

The basic static load rating represents a value at the center of stroke.



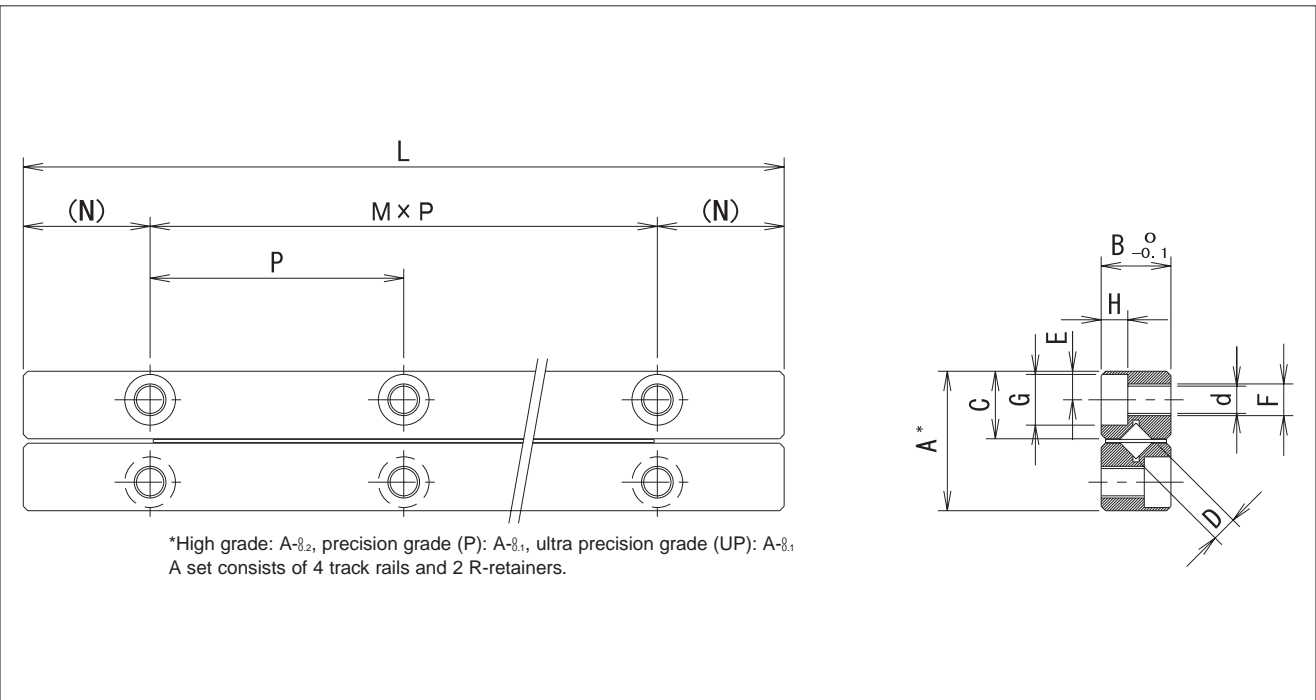

major dimensions						basic load rating		allowable load F N	mass g	size
N mm	E mm	F	d mm	G mm	H mm	dynamic C N	static Co N			
12.5	3.5	M4	3.3	6	3.1	6,150	8,060	2,680	97	<b>3050</b>
						8,440	12,100	4,030	140	<b>3075</b>
						12,500	20,100	6,720	192	<b>3100</b>
						14,400	24,200	8,060	245	<b>3125</b>
						16,300	28,200	9,410	290	<b>3150</b>
						19,800	36,300	12,100	337	<b>3175</b>
20	4.5	M5	4.3	8	4.2	21,500	40,300	13,400	385	<b>3200</b>
						12,100	15,700	5,250	265	<b>4080</b>
						20,700	31,500	10,500	400	<b>4120</b>
						28,500	47,200	15,700	530	<b>4160</b>
						32,000	55,100	18,300	660	<b>4200</b>
25	6	M6	5.2	9.5	5.2	39,000	70,900	23,600	800	<b>4240</b>
						29,600	37,500	12,500	650	<b>6100</b>
						50,900	75,100	25,000	970	<b>6150</b>
						60,600	93,900	31,300	1,300	<b>6200</b>
						69,800	112,000	37,500	1,620	<b>6250</b>
						87,400	150,000	50,100	1,940	<b>6300</b>

1kN ≈ 0.102kgf

# NVT TYPE

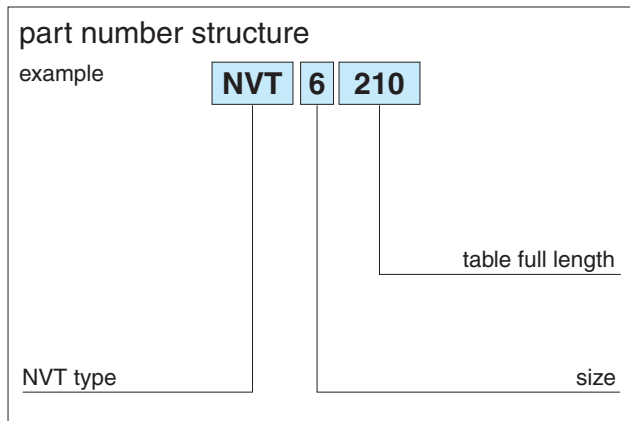

part number	stroke	dimensions				table-top mounting-hole dimensions					table-end mounting-hole dimensions					
	ST mm	A mm	B mm	L mm	b mm	P <sub>1</sub> mm	S <sub>1</sub>	ℓ <sub>a</sub> mm	N mm	M×P mm	h <sub>1</sub> mm	h <sub>2</sub> mm	t <sub>1</sub> mm	t <sub>2</sub> mm	S <sub>2</sub>	ℓ <sub>b</sub> mm
NVT3055	30	28 <sup>±0.1</sup>	60 <sup>±0.1</sup>	55	18.5	25	M4	8	27.5	—	40	—	5.5	—	M3	6
NVT3080	45			80						1×25						
NVT3105	60			105						2×25						
NVT3130	75			130						3×25						
NVT3155	90			155						4×25						
NVT3180	105			180						5×25						
NVT3205	130			205						6×25						
NVT4085	50	35 <sup>±0.1</sup>	80 <sup>±0.1</sup>	85	24	40	M5	10	42.5	—	55	—	6.5	—	M3	6
NVT4125	75			125						1×40						
NVT4165	105			165						2×40						
NVT4205	130			205						3×40						
NVT4245	155			245						4×40						
NVT6110	60	45 <sup>±0.1</sup>	100 <sup>±0.1</sup>	110	31	50	M6	12	55	—	60	92	8	15	M4	8
NVT6160	95			160						1×50						
NVT6210	130			210						2×50						
NVT6260	165			260						3×50						
NVT6310	200			310						4×50						

The basic static load rating represents a value at the center of stroke.

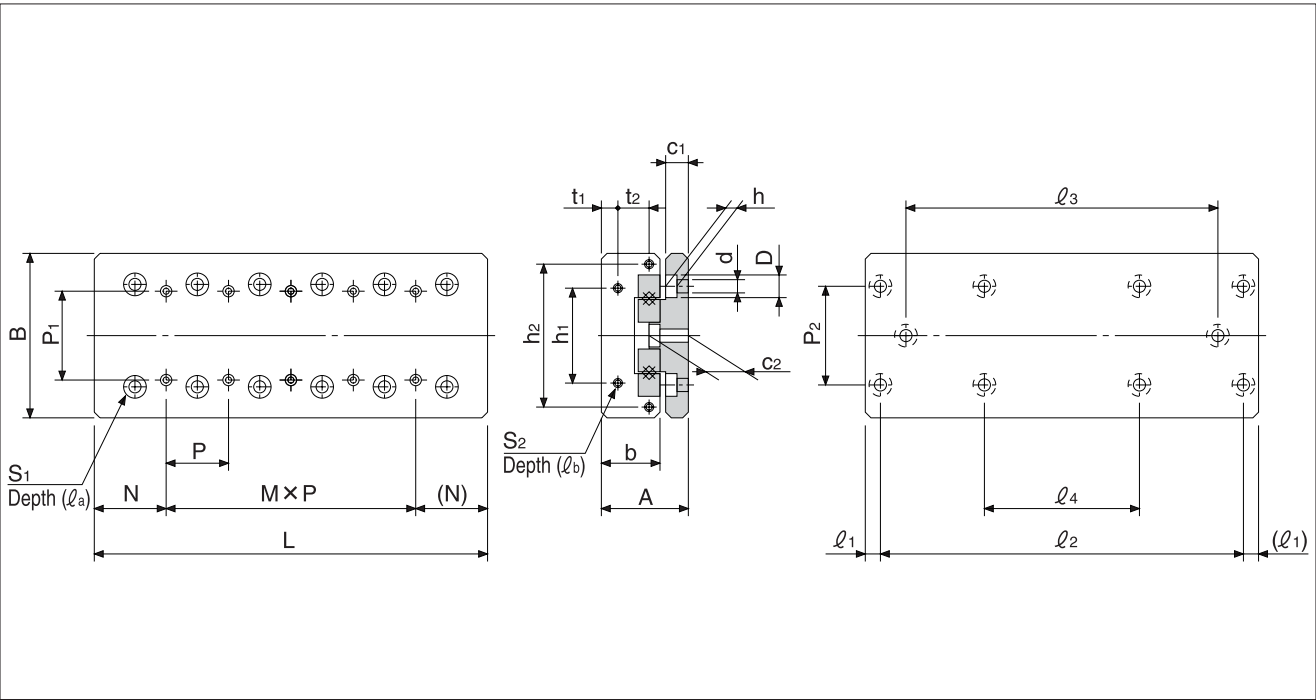

bed-surface mounting-hole dimensions								motion accuracy*		basic load rating			allowable static moment			mass	
P <sub>2</sub> mm	d×D×h mm	c <sub>1</sub> mm	c <sub>2</sub> mm	l <sub>1</sub> mm	l <sub>2</sub> mm	l <sub>3</sub> mm	l <sub>4</sub> mm	T μm	S μm	C N	Co N	F N	M <sub>P</sub> N·m	M <sub>Y</sub> N·m	M <sub>R</sub> N·m	g	size
40	4.5×8×4.5	9	15	10	35	—	—	2	5	6,150	8,060	2,680	20.0	23.3	55.9	643	<b>3055</b>
					60	—	—	2	5	8,440	12,090	4,030	48.9	54.3	82.8	960	<b>3080</b>
					85	—	—	3	6	12,500	20,150	6,720	107.0	99.7	110.6	1,260	<b>3105</b>
					110	—	—	3	6	14,400	24,190	8,060	166.0	157.1	138.0	1,580	<b>3130</b>
					135	85	—	3	6	16,300	28,220	9,410	204.9	217.2	173.1	1,860	<b>3155</b>
					160	110	—	3	7	18,100	36,280	10,700	326.5	341.9	229.9	2,160	<b>3180</b>
55	5.5×10×5.4	10.5	18	10	185	135	85	3	7	19,800	40,310	12,100	357.2	371.6	231.6	2,460	<b>3205</b>
					65	—	—	2	5	11,680	15,050	5,250	76.2	68.4	125.5	1,710	<b>4085</b>
					105	—	—	3	6	20,050	30,100	10,500	214.6	198.7	257.2	2,520	<b>4125</b>
					145	—	—	3	7	27,500	45,150	15,700	306.7	330.8	377.3	3,320	<b>4165</b>
					185	105	—	3	7	31,010	52,680	18,300	498.7	527.9	476.8	4,130	<b>4205</b>
60	7×11.5×7	13	23	10	225	145	—	3	7	37,710	67,730	23,600	786.3	822.8	613.3	4,930	<b>4245</b>
					90	—	—	3	6	29,660	37,580	12,500	271.9	244.7	414.7	3,300	<b>6110</b>
					140	—	—	3	6	50,950	75,160	18,700	665.6	614.7	740.2	4,850	<b>6160</b>
					190	90	—	3	7	60,640	93,950	31,300	1,097.4	1,033.6	957.9	6,310	<b>6210</b>
					240	140	—	3	7	69,890	112,740	37,500	1,855.0	1,771.3	1,333.0	7,790	<b>6260</b>
					290	190	—	3	7	87,440	150,320	43,800	2,731.7	2,638.8	1,665.0	9,260	<b>6310</b>

\*For accuracy T and S, see page H-4.

1kN ≅ 102kgf 1N·m ≅ 0.102kgf·m

