

Miniature Slide Table SYBS Type

The NB miniature slide table SYBS type is a limited stroke slide with the most compact envelope dimensions, featuring two ball raceway grooves. The SYBS type utilizes ball as the rolling elements. The ultra compact design contributes greatly to the creation of smaller and lighter industrial machinery and equipment of all types.

Structure and Advantages

NB's miniature slide table incorporates a unique integrated ball cage between the table and bed. All components have been produced with high precision machining technologies.

Ultra Compact Design

The table height of the SYBS type is 3.2 ~ 4.5mm and the width is 6 ~ 12mm. This compact envelope when compared with conventional slide tables helps to realize the miniaturization of machinery and equipment.

Low Friction - Low Noise

Since the rolling ball elements do not re-circulate, the frictional resistance will not vary significantly resulting in smooth operation reliable high precision.

Additionally, the caged balls greatly reduce the contact noise of the rolling elements bringing about a low-noise operation.

High Accuracy

The ball raceway grooves of the bed and table are processed through simultaneous precision machining resulting in minimal processing errors, and bringing about extremely smooth, precision linear movement.

Stainless Steel Structure

The SYBS type slide table is constructed from only stainless steel materials. This allows for use in corrosive or high temperature applications. The SYBS is a perfect component for vacuum or clean room type environments.

Figure H-27 Structure of SYBS Type Slide Table

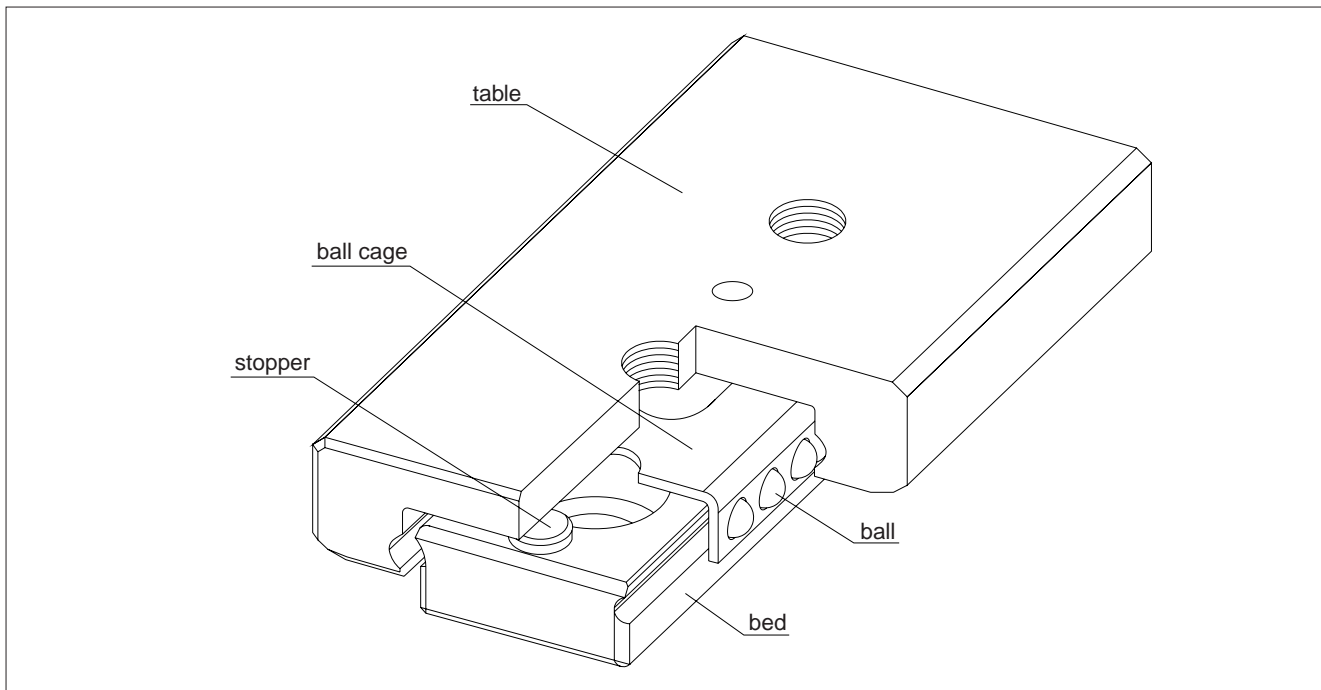

Accuracy

Table H-9 reflects the measured accuracies of the SYBS Miniature Slide Table. The deviation is measured as Figure H-28 illustrates. Dial indicators are placed to the centers of the table's top and side (opposite side from the NB mark) and then the table is moved the full travel distance without any load.

Table H-9 Accuracy Unit: mm

Item	Tolerance and Acceptable Values
Height (H)	±0.020
Width (W)	±0.025
Deviation from Center of Surface C	0.004
Deviation from Center of Surface D	0.006

Figure H-28 Accuracy Measurement Method

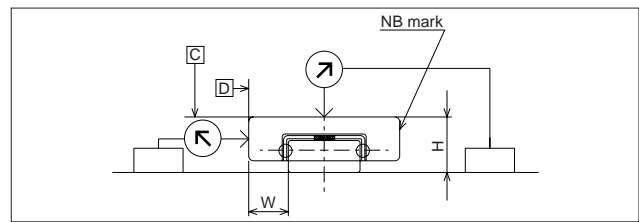

Load Rating

The load capacity of the Miniature Slide Table varies depending upon the direction of the applied load.

Table H-10 Variation of Load Rating vs. Direction of Load

Basic Dynamic Rated Load	Vertical Direction	1.00 x C
	Horizontal Direction	1.13 x C
Basic Static Rated Load	Vertical Direction	1.00 x C ₀
	Horizontal Direction	1.19 x C ₀

Figure H-29 Direction of Load

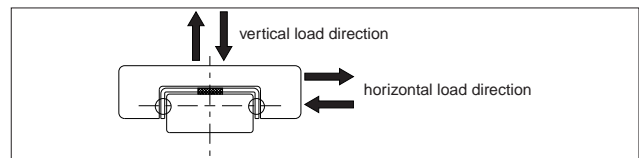

Rated Life

The life of an NB miniature slide table can be calculated using the following equations:

Travel life:

$$L = \left(\frac{f_T}{f_w} \cdot \frac{C}{P} \right)^3 \cdot 50$$

L: travel life (km) f_T : temperature coefficient f_w : load coefficient

C: basic dynamic load (N) P: applied load (N)

※Refer to page Eng-5 for the coefficients

Life Time:

$$L_h = \frac{L \cdot 10^3}{2 \cdot \ell_s \cdot n_1 \cdot 60}$$

L_h: life time (hr) s: stroke length (m)

n₁: number of strokes per minute (cpm)

Mounting

Shape of Mounting Surface

In most general installations, the Miniature Slide Table is mounted by pushing the reference planes of the bed and table against a shoulder that is set up on the mounting surface. Machined escape grooves should be used in the corners of the shoulder (as illustrated in Figure H-30) so that the corners will not interfere with the reference corners of the bed and/or table. Table H-11 lists the recommended shoulder heights of the mounting reference planes for the opposing sides.

When installing the Miniature Slide Table without providing machined escape grooves, the corner radius may be realigned as illustrated in Figure H-31. Table H-12 list the values of the corner radius of the mounting surfaces.

Figure H-30 Shape of Mounting Surface -1

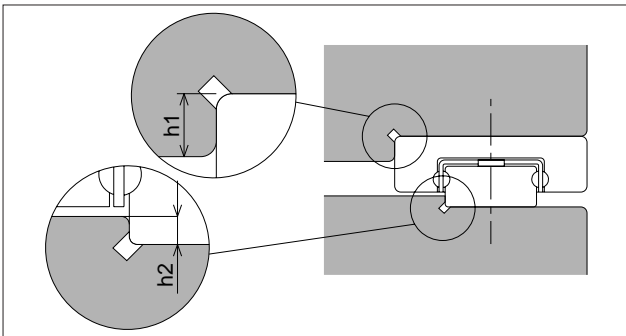

Table H-11 Shoulder Height of Mounting Reference Surfaces Unit: mm

Part Number	Shoulder Height of Table h1	Shoulder Height of Bed h2
SYBS 6	1.0	0.5
SYBS 8	1.2	0.8
SYBS 12	1.5	0.8

Figure H-31 Shape of Mounting Surface -2

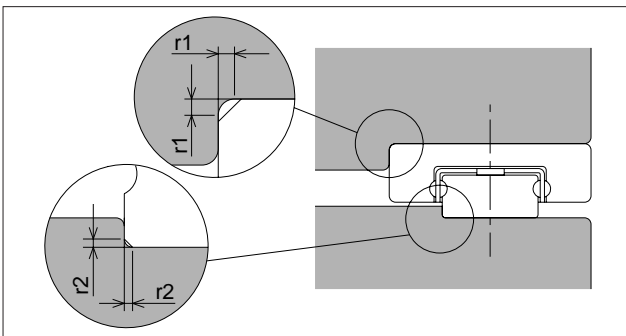

Table H-12 Maximum Corner Radius Unit: mm

Part Number	Mounting Surface of Table	Mounting Surface of Bed
	r1	r2
SYBS 6	0.1	0.05
SYBS 8	0.15	0.1
SYBS 12	0.15	0.1

Recommended Torque Values

The bed should be tightened with a consistent torque by using a torque wrench. Table H-13 lists the recommended tightening torque values:

Table H-13 Recommended Torque Value Unit: N·m

Part Number	Nominal Bolt	Recommended Torque
SYBS 6	M1	0.03
SYBS 8	M1.6	0.15
SYBS 12	M2	0.31

Figure H-32 Shape of SYBS Bed

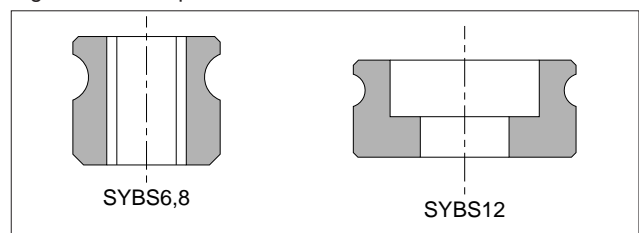

Precautions for Use

Mounting Example and Mounting Screws

All taps used for mounting the SYBS are fully through-hole. Mount the SYBS type as illustrated in Figure H-33 only after considering the size of mounting screw, the maximum penetration depth, and the height of the bed. Make certain that the mounting screws do not interfere with the ball cage; otherwise, the accuracy and travel life of this table will be affected adversely. Special bolts are designed for SYBS type and are available from NB. Please refer to Table H-14 for dimensions of these special mounting screws.

Figure H-33 Mounting Example

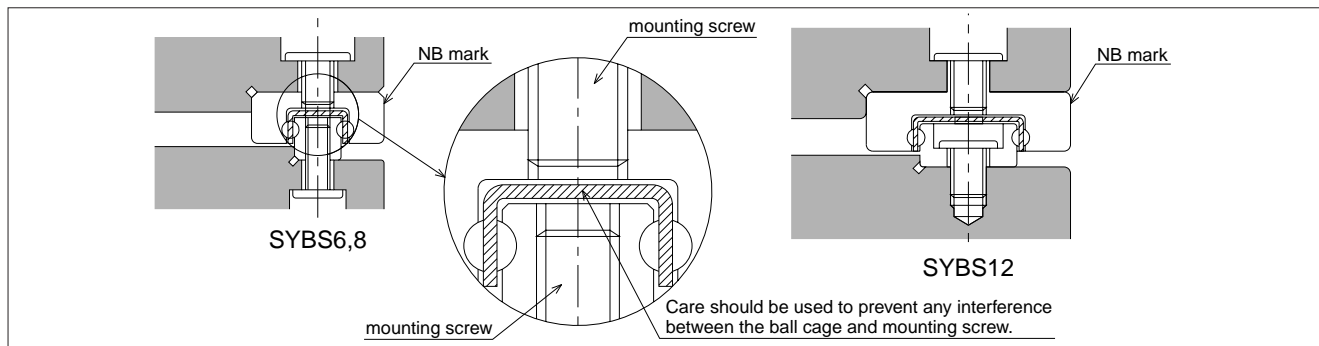

Table H-14 Mounting Screws (Material: Stainless Steel) Unit: mm

M (Nominal Bolt)	D	H	Pitch	L
M1	1.8	0.5	0.25	5
M1.4	2.5	0.5	0.3	6
M1.6	2.3	0.5	0.35	4,5,6
M2	3	0.6	0.4	6

Stopper

On both ends of the SYBS Miniature Slide Table bed section, stopper screws have been attached to prevent the ball cage from escaping. Please note that the screws are designed only to prevent the ball cage from escaping and are not intended for the use as a mechanical stopper. The ball cage may become deformed on contact with the stopper and this will result in a negative affect of the accuracy and rated life of the table.

Lubrication

NB's Miniature Slide Table SYBS Type is supplied with an initial application of lithium soap grease and therefore is ready for immediate use. Periodic application of a similar lubricant should be necessary depending on the operating conditions. For use in clean rooms or vacuum environments, miniature slide tables without grease or with customer specified grease are available. NB also provides low dust generation lubricant. Please refer to page Eng-20 for further details.

Figure H-34 Mounting Screw

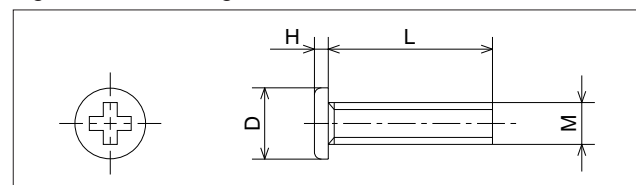

Ball Cage Displacement

When a miniature slide table is operated at high speeds; when offset loads or vibrations are present, the ball cage may deviate from the normal position. In general operating conditions this is normal and it is recommended that the table be cycled to perform maximum full stroke travel several times during operation. This will allow the ball cage to be returned to its normal central position.

Pre-Load

The SYBS Miniature Slide Table is prepared with only a slight positive-clearance.

Allowable Load

The allowable load is a load under which the sum of elastic deformation of the rolling element and the raceway in the contact area subject to the maximum contact stress is small enough to guarantee smooth rolling movement. Where very smooth and highly accurate liner motion is required, make sure to use the product within the allowable load values.

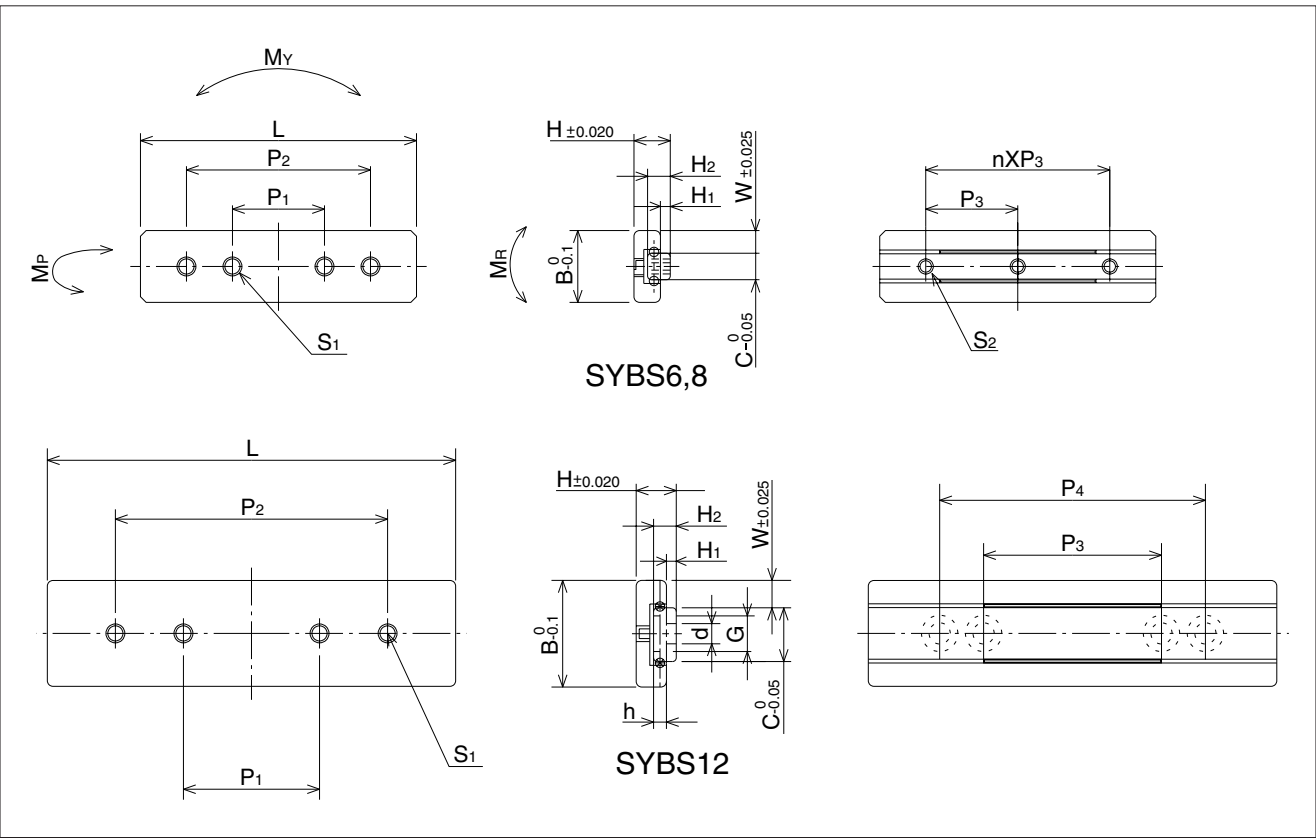

bed-surface mounting-hole dimensions							basic load rating		allowable load	allowable static moment			mass	size
H ₂	C	d×G×h	S ₂	P ₃	n	P ₄	dynamic	static		F	M _P	M _V		
mm	mm	mm		mm		mm	N	N	N	N·m	N·m	N·m	g	
2.0	2	—	M1	7	1	—	154	180	60.1	0.21	0.25	0.21	1.4	6—13
				7	2	—	229	315	105	0.57	0.698	0.37	2.2	6—21
2.6	3	—	M1.6	5	1	—	201	211	70.4	0.23	0.28	0.35	2.0	8—11
				10	1	—	368	493	164	1.02	1.22	0.83	3.7	8—21
				10	2	—	473	704	234	1.97	2.35	1.19	5.5	8—31
2.6	6	※1 2.4×4×1.5	—	15	1	—	404	563	187	1.30	1.55	1.80	7.6	12—23
				15	1	—	473	704	234	1.97	2.35	2.25	10.2	12—31
				20	—	30	658	1,120	375	4.80	5.72	3.60	15.2	12—46