

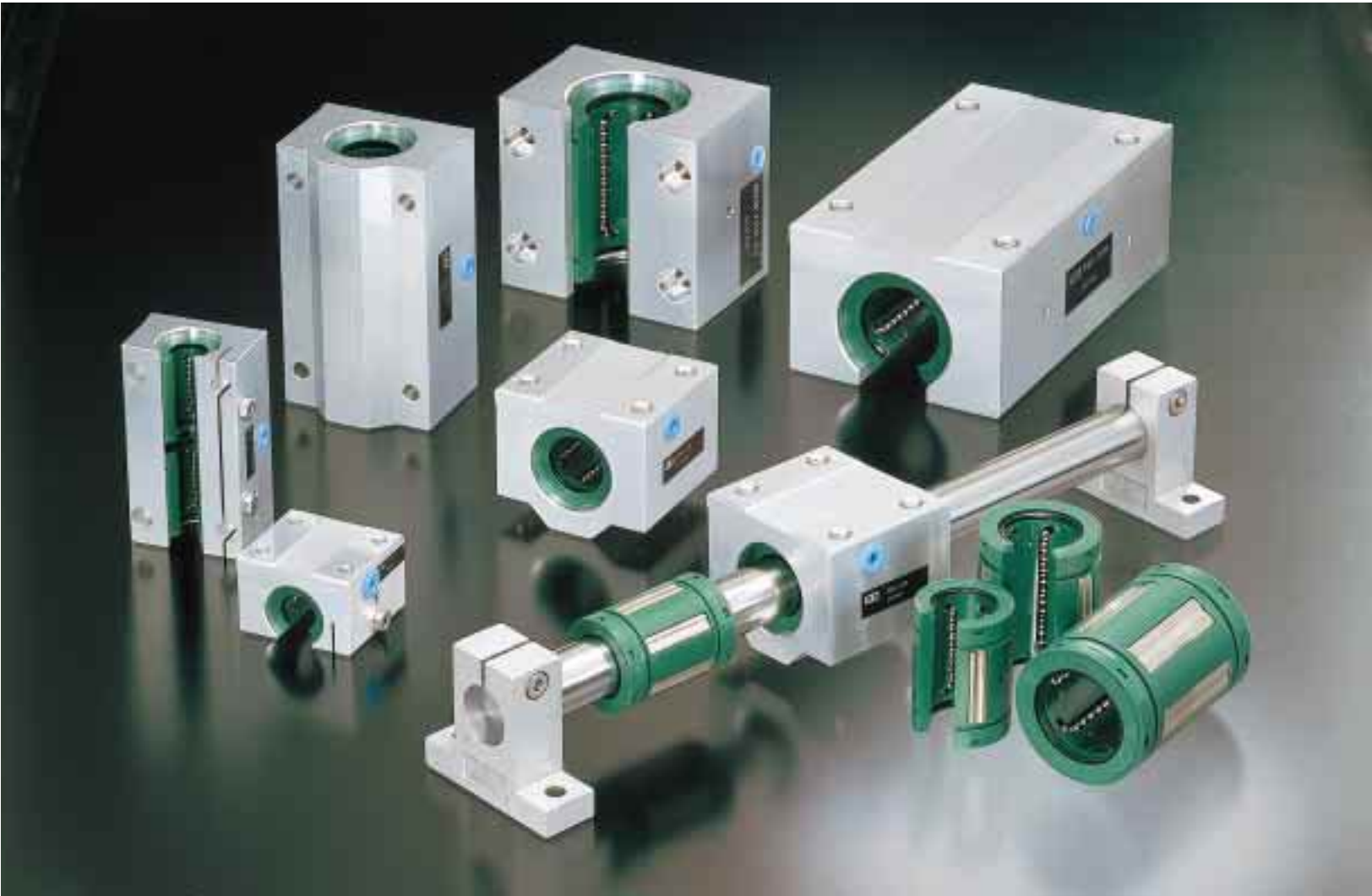

TOPBALL SLIDE PRODUCTS

TK Metric series



 **NIPPON BEARING CO., LTD.**

NB SLIDE BUSH TOPBALL[®] Metric Series

Nippon Bearing Co., Ltd. now offers a new standard in linear motion with **TOPBALL**. The **TOPBALL** slide bush is a high performance bushing with three times the load capacity, capable of providing up to 27 times normal travel life of a conventional slide bushing.

TOPBALL is available in a variety of configurations to fit various service conditions. **NB**'s self-aligning **TOPBALL** can be designed into many different

applications such as factory automated equipment, machine tools, industrial machines, electrical equipment, optical and measuring instruments.

In the early stages of **NB**'s development of **TOPBALL**, careful thought and consideration was given to such factors as quality, cost, performance and interchangeability. The results of these efforts are reflected in the **TOPBALL** features.

TOPBALL Features

1. Increased Load Capacity

NB's uniquely designed ground load plate provides circular arch contact to the ball resulting in a greater dispersion of the load, enabling TOPBALL to provide three times the load capacity of conventional slide bushings.

2. Longer Travel Life

Dispersed stress on the load plate provides TOPBALL up to 27 times the travel life of conventional slide bushings.

3. Self Aligning Capability

Load plates are thinner at the ends to provide a pivot point at the center of the plate. The center acts as a fulcrum to compensate for any slight misalignment between the shaft and the housing bore that might be caused by inaccurate machining, mounting errors or shaft deflection.

4. Floating Integral Wiper Seal

NB's unique floating seal design allows for self-alignment while maintaining equal and constant contact to the shaft. Seals do not add to the overall length of the bushing allowing for more compact designs.

5. Clearance Adjustable

TOPBALL load plates are designed to "float" in the outer sleeve which allows for clearance between the balls and shaft to best suit application requirements

6. Cost Effectiveness

TOPBALL's higher load capability and longer travel life enables the use of smaller components such as bushings, housings and shafts, reducing material cost and the overall cost of the system. Longer travel life also extends replacement periods and reduce maintenance cost.

Fig.1 Illustrating circular arch design and ground surface raceway

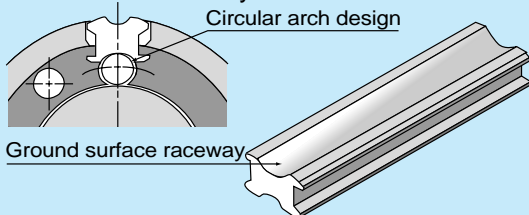
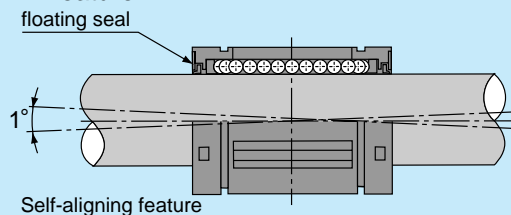

Fig.2 Illustrating floating seal and self-aligning feature



TOPBALL Types



Standard type

Floating load plate design features adjustable clearance, self-alignment ability and a light weight outer ring and retainer for low noise operation.

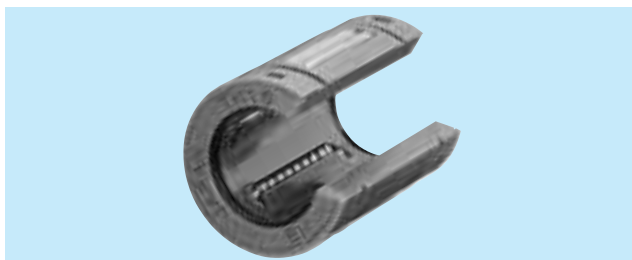

Open type

One ball circuit is removed from the outer cylinder enabling it to be used with bottom supported shaft to eliminate shaft deflection. The open type TOPBALL is also considered clearance adjustable.



Sealed type

NB's unique integral design creates a free floating action of the wiper seal apart from the bushing itself, providing extremely smooth operation. All TOPBALL types are available with this feature.

Anti-corrosive

A special TOPBALL is also available for corrosive applications. Contact your nearest distributor for application information.

Type Number Format

Each TOPBALL bushing is stamped with a code providing useful information regarding its type, series, size, seals and modifications. The key to that code is as follows.

Example

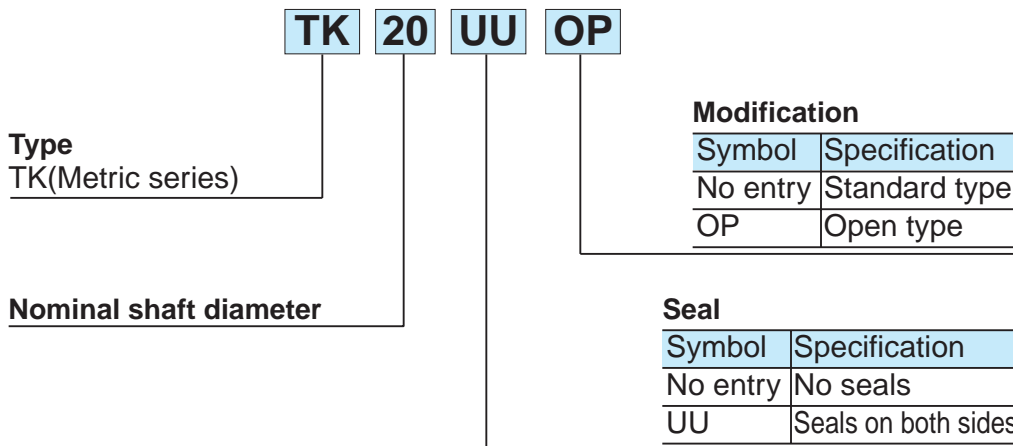

Slide Bush Life

The life of a slide bush can be easily calculated with the load rating of the bush, shaft hardness and applicable load. However, in many cases, slide bushing failure may be caused by improper design of peripherals, including the shaft and housing, inappropriate mounting or improper operation. Serious consideration of these peripheral factors, in addition to load rating, are highly recommended when designing a slide bush application.

Basic Dynamic Load Rating and Life Expectancy

The basic dynamic load rating is the load which allows a rating life of 50km, without changing its magnitude and direction. The rating life can be obtained from the following equation.

$$L = \left(\frac{C}{P} \right)^3 \cdot 50 \quad \text{Equation (1)}$$

L: Rating life (km)

C: Basic dynamic load rating (N)

P: Load (N)

Chart 1 shows the relationship between rating life (L) and load ratio (C/P). In the practical use of a bushing, other factors that affect the life, such as shaft hardness and load condition should be considered. The equation for calculating bushing life considering these additional factors is:

$$L = \left(\frac{f_h \cdot C}{f_w \cdot P} \right)^3 \cdot 50 \quad \text{Equation (2)}$$

f_h : Hardness factor (See Chart 2)

f_w : Load coefficient (See Table 1)

Rating life in hours can be calculated by obtaining the travelling distance per unit of time as follows:

$$L_h = \frac{L \cdot 10^3}{2 \cdot L_s \cdot N1 \cdot 60} \quad \text{Equation (3)}$$

L_h : Rating life in hours (hr)

L_s : Stroke length (m)

$N1$: Rate of cycles per minute

L: Rating life (km)

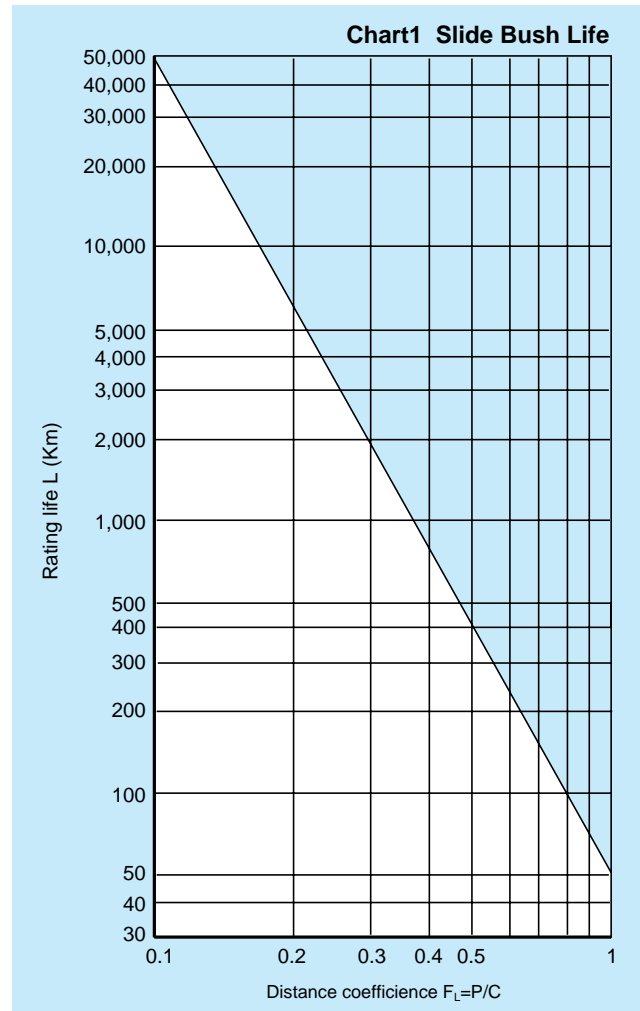

Load coefficient (fw)

When calculating the bush load, it is necessary to accurately obtain weight, inertial force based on speed, moment load and each transition as time passes. However, it is difficult to calculate those values accurately because reciprocating motion involves the repetition of starts and stops as well as vibration and impact. A more practical approach is to obtain the load coefficient by taking the actual operating conditions into account.

Table 1: Load Coefficient

OPERATING CONDITIONS	f _w
Operation at low speed (15m/min. or less) without impulsive shock from outside	1.0-1.5
Operation at intermediate speed (60m/min. or less) without impulsive shock	1.5-2.0
Operation at high speed (over 60m/min.) with impulsive shock	2.0-3.5

Hardness Factor (fh)

The shaft must be hardened to 60~65HRC when a slide bush is used. If not properly hardened, permissible load is lowered and the life of the bushing will be shortened.

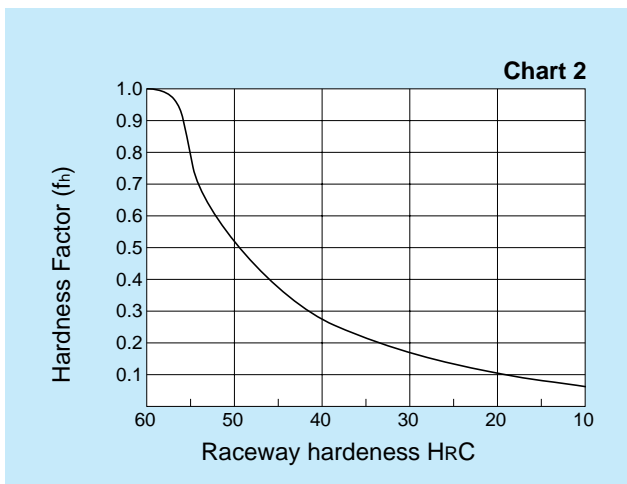

Examples of Calculations:

(1) Life expectancy when **NB's** TOPBALL TK 25 is used under the following conditions:

- Load per bush: 668N
- Stroke distance: 0.2m
- Rate of cycles/min: 35
- Shaft hardness: 60HRC

From the basic dynamic load of TK25 is 3780N. hardness factor(fh) is 1.0, and the operating speed can be calculated as 0.014km/min. Therefore, the load coefficient(f_w) is considered as 1.0.

Using equation (2) (Page 3)

$$L = \left(\frac{3780}{668} \right)^3 \cdot 50 = 9,060 \text{ km}$$

Using equation (3) (Page 3)

$$L_h = \frac{9,060}{2 \cdot 0.2 \times 10^{-3} \cdot 35 \cdot 60} = 10,800 \text{ hours}$$

(2) Selection of size for the application as follows:

- Expected life: 15,000 hours
- Number of bushings in the carriage: 4
- Gross weight on the carriage: 668N
- Stroke distance: 0.0009km
- Traveling speed: 0.03km/min.
- Shaft hardness: 60-64HRC

From equation (3), the life expected in traveling distance is:

$$L = 15,000 \cdot 2 \cdot 0.03 \cdot 60 = 27,000 \text{ km} (2.7 \times 10^4)$$

$$C = \sqrt[3]{\frac{27000}{50}} \cdot \left(\frac{f_w}{f_h} \right) \cdot P = 2040 \text{ N}$$

From the equation (2),

Note that: fh=1.0, fw=1.5, P=668/4=167N

As result, the TOPBALL that is able to handle this load is: TK20.

Basic Static Load Rating

If a slide bush is loaded when it is in a stationary condition or working at low speed, a permanent elastic deformation is formed on the rolling element. The deformation prevents smooth movement of the bushing. To eliminate this possibility, the basic static load rating must not be exceeded.

Relation Between Ball Circuits and Load Rating

The load rating of a slide bush varies according to the loaded position on the circumference. The value in the dimensional table indicates the lowest load rating with the load placed on top of one ball circuit. If the slide bush is used with two ball circuits loaded uniformly, the value will be greater. Table 2 shows the load ratio for the number of ball circuits in each case.

Clearance and Fit

An appropriate clearance between the slide bush and shaft is required in TOPBALL operation. Inadequate clearance may cause early failure and/or poor, rough movement. Proper clearance is determined by shaft diameter and housing bore. Table 3 shows **NB**'s recommended tolerances of the shaft and housing bore in order to maintain the appropriate clearance.

Table 2: Optional Load Positions

NUMBER OF ROWS	4	5	6
C (LOAD RATING SPECIFIED ON THE TABLE)			
C _{max} (MAXIMUM LOAD RATING)			
LOAD RATIO C _{max} /C	1,414	1,463	1,280

Table 3: Recommended Tolerance for Shaft O.D. and Housing Bore

Part Number	Shaft Dia.		Housing Bore	
	dr mm	Tol.(h6) μm	D mm	Tol.(H7) μm
TK10	10	0 -11	19	+21 0
TK12	12		22	
TK16	16		26	
TK20	20	0 -13	32	+25 0
TK25	25		40	
TK30	30		47	
TK40	40	0/-16	62	+30/0

Shaft and Housing

To optimize **NB TOPBALL** performance, high precision shafts and housings are required.

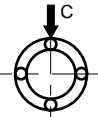
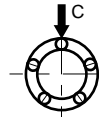
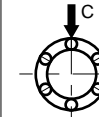
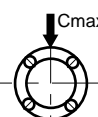
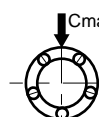
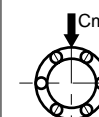
1. Shaft: Dimensional tolerance, surface finish and hardness greatly affect the traveling performance of the **TOPBALL**. The shaft must be manufactured to the following tolerances.

- A. A surface finish of 0.4Ra or less.
- B. Hardness of HRC 60 or more. Hardness less than HRC 60 decreases the life considerably and reduces the permissible load.
- C. The correct tolerance of the shaft diameter is recommended on Table 3 (Page 5).

The **NB** Slide Shaft is an ideal component manufactured to these specifications. For details, please refer to the **NB** general catalog.

2. Housing: There are a wide range of designs and manufacturing techniques for mounted housings. **NB** pre-engineered slide units are also available. For proper fit refer to Table 3 (Page 5).

Mounting

TOPBALL is designed to be press fitted into the housing bore. When inserting bushing, however, don't apply excess force nor shock load which may cause permanent damage.

Examples of Mounting

The following examples (Figs. 3 to 6) illustrate assembly of the inserted bush as they should be designed and mounted.

Fig.3 Use of holding plates

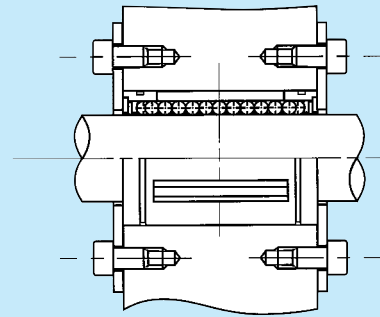

Fig.4 Adjustable type housing

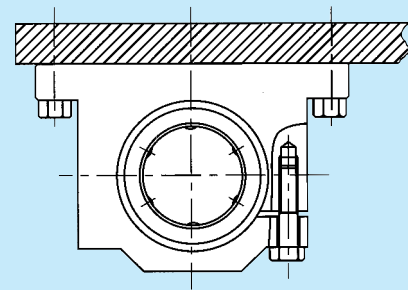

Fig.5 Use of external retaining rings

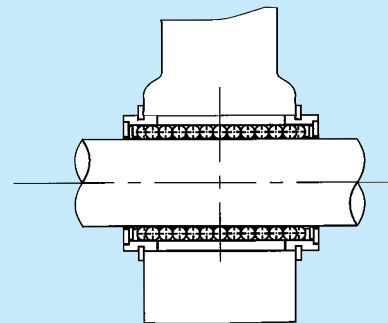
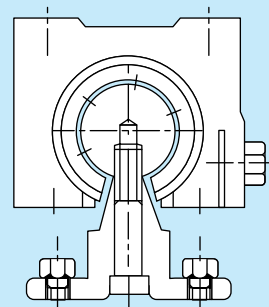
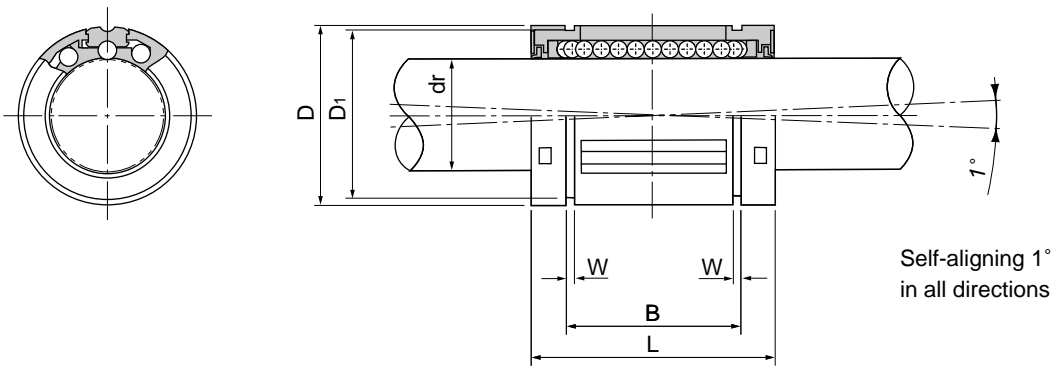
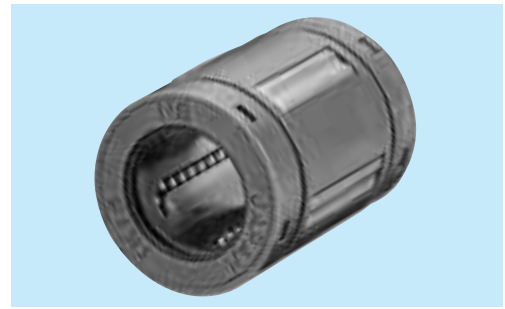

Fig.6 Open type housing



TOPBALL



Nom. shaft dia. mm	Closed type			Open type			Working diameter		Nom.O.D. D mm	L	
	P/N	No. of ball circuits	wght. g	P/N	No. of ball circuits	wght. g	dr mm	tol.(1) μm		mm	tol. mm
10	TK10	5	14	—	—	—	10	+ 8	19	29	±0.2
12	TK12	5	21	TK12-OP	4	17	12	0	22	32	
16	TK16	5	43	TK16-OP	4	35	16	+ 9	26	36	
20	TK20	6	58	TK20-OP	5	48	20	- 1	32	45	
25	TK25	6	123	TK25-OP	5	103	25	+11	40	58	
30	TK30	6	216	TK30-OP	5	177	30	- 1	47	68	
40	TK40	6	333	TK40-OP	5	275	40	+13/-2	62	80	

(1) Based on nominal housing bore

Seal type
Example

TK **20** **UU** **OP**

No entry	No seals
UU	Seals on both sides

TK 12-OP

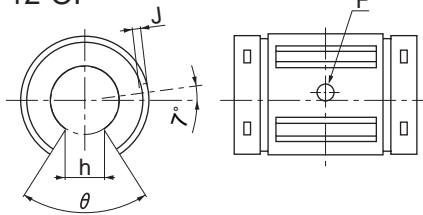

TK 16-OP, TK 20-OP

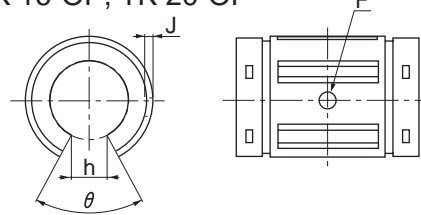

TK 25-OP

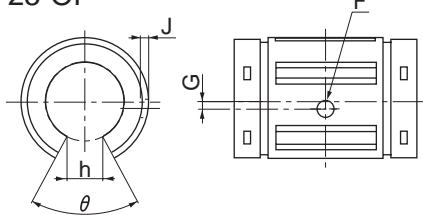

TK 30-OP, TK 40-OP

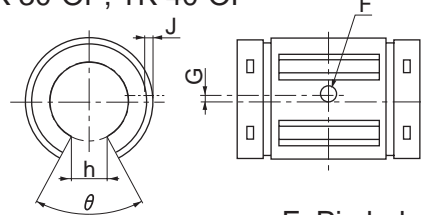

F: Pin hole

Major dimensions									Basic load rating		Nom. shaft dia. mm
B mm	tol. mm	W mm	D1 mm	Open type					Dyn. C N	Stat. Co N	
				h mm	θ	F ^{H11} mm	G mm	J mm			
22.0	0 -0.2	1.3	18	—	—	3	—	—	750	935	10
22.9		1.3	21	6.5	66°		—	0.7	1020	1290	12
24.9		1.3	24.9	9	68°		—	1.0	1250	1550	16
31.5		1.6	30.3	9	55°		—	1.0	2090	2630	20
44.1	0 -0.3	1.85	37.5	11.5	57°		1.5	1.5	3780	4720	25
52.1		1.85	44.5	14	57°		2	2.2	5470	6810	30
60.6		2.15	59	19.5	56°		1.5	2.7	6590	8230	40

1N \approx 0.102kgf

NB TOPBALL® Slide Unit

Introduction/Design Features





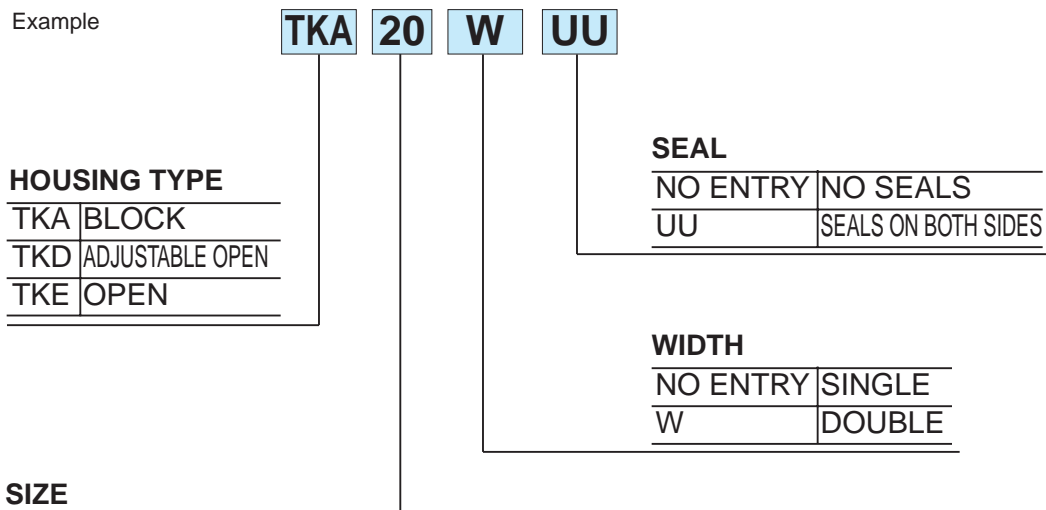

NB TOPBALL Slide Units consist of a clear anodized corrosion resistant aluminum block and either one or two **TOPBALL** self-aligning slide bushings. All styles are provided with standard machined reference edges for proper alignment and installation.

Type Number Format

Each TOPBALL slide unit is stamped with a code providing useful information regarding its type, series, size, seals and modifications. The key to that code is as follows.



Types

SINGLE	DOUBLE
<ul style="list-style-type: none"> • Conventional type • Self-aligning capability • Oiling feature available (TKA Size20~40) • High load capacity 	<ul style="list-style-type: none"> • Compact tandem design • Oiling feature available • Double capacity compared with single type units
<p>TKA</p> 	<p>TKA-W</p> 
<p>TKE</p> 	<p>TKE-W</p> 
<p>TKD</p> 	<p>TKD-W</p> 

TOPBALL

TKA Block type

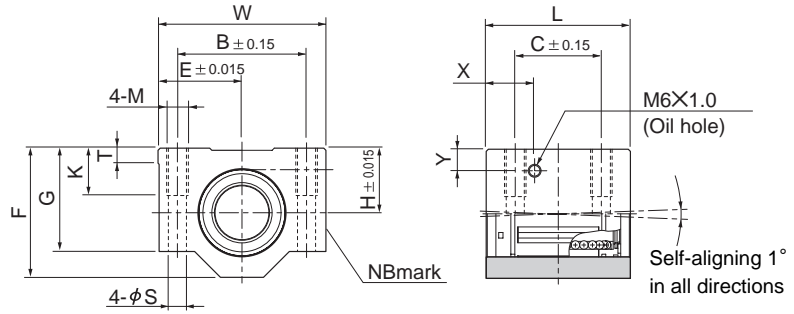

Part No.	Nom. Shaft dia. mm	Major dimensions									Mounting dimensions					Load rating		Wt. g
		H mm	E mm	W mm	L mm	F mm	G mm	T mm	X mm	Y mm	B mm	C mm	M mm	K mm	S mm	Dynamic C N	Static Co N	
TKA12UU	12	18	21.5	43	39	35	28	5	—	—	32	23	M5	11	4.3	1020	1290	116
TKA16UU	16	22	26.5	53	43	42	35	5	—	—	40	26	M6	13	5.3	1250	1550	205
TKA20UU	20	25	30	60	54	50	42	5	19	9	45	32	M8	18	6.6	2090	2630	326
TKA25UU	25	30	39	78	67	60	48	7	22.5	10	60	40	M10	22	8.4	3780	4720	624
TKA30UU	30	35	43.5	87	79	70	58	8	26	11.5	68	45	M10	22	8.4	5470	6810	980
TKA40UU	40	45	54	108	91	90	72	10	26.5	14	86	58	M12	26	10.5	6590	8230	1670

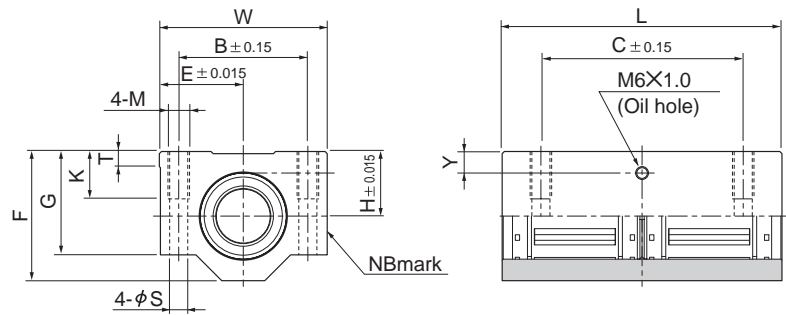

Part No.	Nom. Shaft dia. mm	Major dimensions									Mounting dimensions					Load rating		Wt. g
		H mm	E mm	W mm	L mm	F mm	G mm	T mm	Y mm	B mm	C mm	M mm	K mm	S mm	Dynamic C N	Static Co N		
TKA12WUU	12	18	21.5	43	76	35	28	5	7.5	32	56	M5	11	4.3	1652	2580	227	
TKA16WUU	16	22	26.5	53	84	42	35	5	9.5	40	64	M6	13	5.3	2025	3100	390	
TKA20WUU	20	25	30	60	104	50	42	5	9	45	76	M8	18	6.6	3390	5260	630	
TKA25WUU	25	30	39	78	130	60	48	7	10	60	94	M10	22	8.4	6120	9440	1210	
TKA30WUU	30	35	43.5	87	152	70	58	8	11.5	68	106	M10	22	8.4	8860	13620	1880	
TKA40WUU	40	45	54	108	176	90	72	10	14	86	124	M12	26	10.5	10680	16460	3280	

TKE Open type

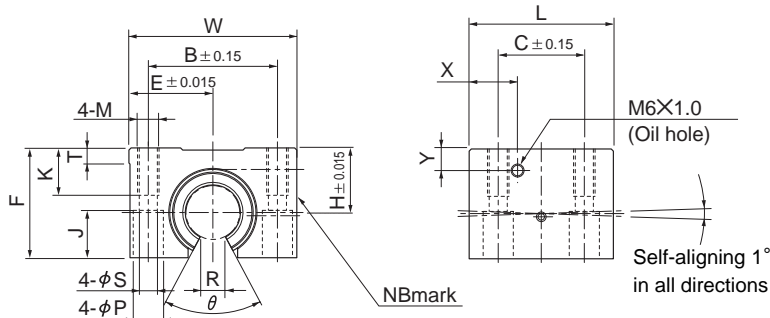

Part No.	Nom. Shaft dia. mm	Major dimensions									Mounting dimensions								Load rating		Wt. g
		H	E	W	L	F	T	R	θ	X	Y	B	C	M	K	S	P	J	Dynamic C N	Static Co N	
TKE12UU	12	18	21.5	43	39	28	5	6.5	66°	14.5	7.5	32	23	M5	11	4.3	8	4.5	1020	1290	99
TKE16UU	16	22	26.5	53	43	35	5	9	68°	15.5	9.5	40	26	M6	13	5.3	9.5	5.5	1250	1550	175
TKE20UU	20	25	30	60	54	42	5	9	55°	19	9	45	32	M8	18	6.6	11	6.5	2090	2630	275
TKE25UU	25	30	39	78	67	51	7	11.5	57°	22.5	10	60	40	M10	22	8.4	14	8.6	3780	4720	558
TKE30UU	30	35	43.5	87	79	60	8	14	57°	26	11.5	68	45	M10	22	8.4	14	8.6	5470	6810	860
TKE40UU	40	45	54	108	91	77	10	19.5	56°	26.5	14	86	58	M12	26	10.5	17.5	10.8	6590	8230	1490

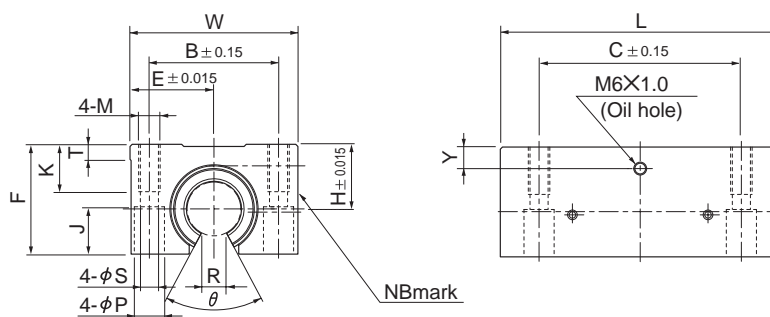

Part No.	Nom. Shaft dia. mm	Major dimensions									Mounting dimensions								Load rating		Wt. g
		H	E	W	L	F	T	R	θ	Y	B	C	M	K	S	P	J	Dynamic C N	Static Co N		
TKE12WUU	12	18	21.5	43	76	28	5	6.5	66°	7.5	32	56	M5	11	4.3	8	4.5	1652	2580	190	
TKE16WUU	16	22	26.5	53	84	35	5	9	68°	9.5	40	64	M6	13	5.3	9.5	5.5	2025	3100	312	
TKE20WUU	20	25	30	60	104	42	5	9	55°	9	45	76	M8	18	6.6	11	6.5	3390	5260	505	
TKE25WUU	25	30	39	78	130	51	7	11.5	57°	10	60	94	M10	22	8.4	14	8.6	6120	9440	1050	
TKE30WUU	30	35	43.5	87	152	60	8	14	57°	11.5	68	106	M10	22	8.4	14	8.6	8860	13620	1630	
TKE40WUU	40	45	54	108	176	77	10	19.5	56°	14	86	124	M12	26	10.5	17.5	10.8	10680	16460	2880	

TOPBALL

TKD Adjustable Open type

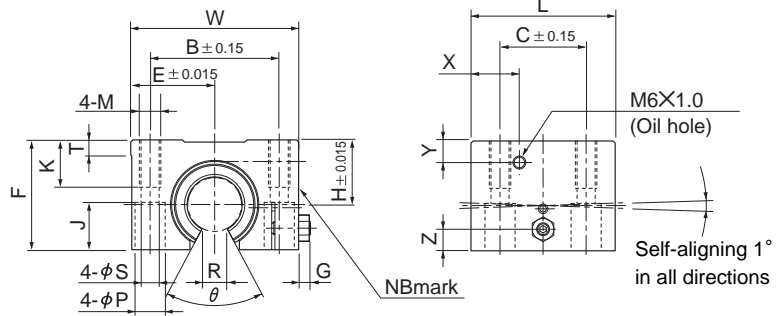

Part No.	Nom. Shaft dia. mm	Major dimensions											Mounting dimensions							Load rating		Wt. g	
		H	E	W	L	F	G	Z	T	R	θ	X	Y	B	C	M	K	S	P	J	Dynamic C N		Static Co N
TKD12UU	12	18	21.5	43	39	28	3.2	5	5	6.5	66°	14.5	7.5	32	23	M5	11	4.3	8	11.5	1020	1290	99
TKD16UU	16	22	26.5	53	43	35	3.2	6	5	9	68°	15.5	9.5	40	26	M6	13	5.3	9.5	14	1250	1550	175
TKD20UU	20	25	30	60	54	42	4	8	5	9	55°	19	9	45	32	M8	18	6.6	11	18	2090	2630	275
TKD25UU	25	30	39	78	67	51	5.5	10	7	11.5	57°	22.5	10	60	40	M10	22	8.4	14	22	3780	4720	558
TKD30UU	30	35	43.5	87	79	60	5.5	12	8	14	57°	26	11.5	68	45	M10	22	8.4	14	26	5470	6810	860
TKD40UU	40	45	54	108	91	77	5	15	10	19.5	56°	26.5	14	86	58	M12	26	10.5	17.5	33	6590	8230	1490

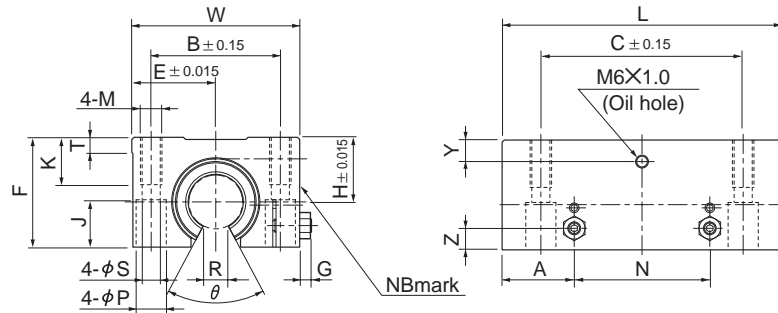

Part No.	Nom. Shaft dia. mm	Major dimensions											Mounting dimensions							Load rating		Wt. g		
		H	E	W	L	F	G	Z	A	N	T	R	θ	Y	B	C	M	K	S	P	J		Dynamic C N	Static Co N
TKD12WUU	12	18	21.5	43	76	28	3.2	5	19.5	37	5	6.5	66°	7.5	32	56	M5	11	4.3	8	11.5	1652	2580	190
TKD16WUU	16	22	26.5	53	84	35	3.2	6	21.5	41	5	9	68°	9.5	40	64	M6	13	5.3	9.5	14	2025	3100	312
TKD20WUU	20	25	30	60	104	42	4	8	27	50	5	9	55°	9	45	76	M8	18	6.6	11	18	3390	5260	505
TKD25WUU	25	30	39	78	130	51	5.5	10	33.5	63	7	11.5	57°	10	60	94	M10	22	8.4	14	22	6120	9440	1050
TKD30WUU	30	35	43.5	87	152	60	5.5	12	39.5	73	8	14	57°	11.5	68	106	M10	22	8.4	14	26	8860	13620	1630
TKD40WUU	40	45	54	108	176	77	5	15	45.5	85	10	19.5	56°	14	86	124	M12	26	10.5	17.5	33	10680	16460	2880

Related Products

End Shaft Support : SHF type

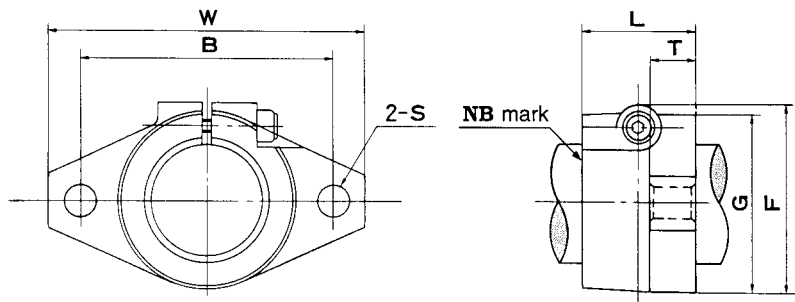

Part No.	Nominal shaft diameter	Major dimensions							Clamping bolt designation	Mounting bolt designation	Wt. g
		W mm	L mm	T mm	F mm	G mm	B mm	S mm			
SHF 10	10	43	10	5	24	20	32	5.5	M5	M4	13
SHF 12	12	47	13	7	28	25	36	5.5	M5	M4	20
SHF 13	13	47	13	7	28	25	36	5.5	M5	M4	20
SHF 16	16	50	16	8	31	28	40	5.5	M5	M4	27
SHF 20	20	60	20	8	37	34	48	7	M6	M5	40
SHF 25	25	70	25	10	42	40	56	7	M6	M5	60
SHF 30	30	80	30	12	50	46	64	9	M8	M6	110
SHF 35	35	92	35	14	58	50	72	12	M10	M8	380
SHF 40	40	102	40	16	67	56	80	12	M10	M10	510
SHF 50	50	122	50	19	83	70	96	14	M12	M12	890
SHF 60	60	140	60	23	95	82	112	14	M12	M12	1500



NIPPON BEARING CO., LTD.

2833 Chiya, Ojiya-city, Niigata-pref., 947-8503 JAPAN
Phone: 81-258-82-0011 Fax: 81-258-81-1135

NB Corporation of America

939 A. E. C. Drive, Wood Dale, IL60191
Phone: (630) 227-1112 Fax: (630) 227-1118
TOLL FREE: 1-800-521-2045

Western Regional office

1214 Alderwood Ave., Sunnyvale, CA94089
Phone: (408) 747-5000 Fax: (408) 747-5100
TOLL FREE: 1-888-562-4175

<http://www.nbcorporation.com>
info@nbcorporation.com

Local Sales Representative: